

Gresgying

F3-EU

120kW/180kW DC Charging Station  
Installation Manual





# Contents

1. Safety Instructions .....	6
1.1 Symbols used in this manual .....	6
1.2 Save these instructions .....	6
1.3 WARNING: Risk of electric shock .....	6
1.4 WARNING: Accumulation of gases .....	7
1.5 CAUTION .....	7
1.6 Charging station safety precautions .....	7
1.7 Safety Labels on the packaging .....	8
2. Introduction .....	10
2.1 Important information .....	10
2.2 Scope of the Document .....	10
2.3 Product Introduction .....	11
2.4 Product Specification .....	12
2.5 List of Tools .....	13
3. Transport and Storage .....	14
3.1 Storage .....	14
3.2 Transport .....	14
3.3 Packed Product Handling .....	14
3.4 Packaging Removal .....	15
3.5 Supplied Components .....	17
4. Product Handling .....	18
4.1 Handling with a forklift .....	18
4.2 Handling by crane .....	18
5. Product Features .....	20
5.1 Product Parts .....	20
5.2 Nameplate .....	21
6. Preparation for Installation .....	23
6.1 Safety precautions .....	23
6.2 Plan installation .....	23
6.3 Select location .....	23
6.4 Parking space placement .....	24





6.5 Cooling .....	25
6.6 Clearance .....	26
6.7 Foundations .....	27
6.8. Implantation plan .....	27
6.9 Route power supply cables .....	29
6.10 Protection against electric shock and short circuits .....	29
6.11 Electrical requirements .....	29
6.11.1 Upstream requirements .....	29
6.11.2 Grounding Instructions .....	30
7. Install the Gresgying F3-EU .....	30
7.1 Handling .....	30
7.2. Open the door of the Gresgying F3-EU .....	30
7.3 Remove the lower plastic cover .....	31
7.4 Remove the left and right plinth and the wooden pallet .....	33
7.5 Placing .....	35
7.6 Electrical Connections .....	37
8. Commissioning .....	38
8.1 Preparation for Power on .....	38
8.2 power on the charging station .....	38
9. Use of the Gresgying F3-EU .....	39
9.1 Start Charging .....	40
9.2 Stop charging .....	43
9.3 Charging by online or offline .....	45
10. SOC Display .....	48
11. Decommissioning .....	49
12. Preventive Maintenance .....	50
13. Troubleshooting .....	51



# 1. Safety Instructions

Read and observe the following safety precautions before you install, service, or use your Gresgying charging station. The installer must ensure that the charging station is installed in accordance with the relevant country-specific standards, and local regulations.

## 1.1 Symbols used in this manual

Symbol	Explanation
	<b>DANGER:</b> Indicates an imminently hazardous situation with a high risk of level which, if the danger is not avoided, will cause death or serious injury.
	<b>WARNING:</b> Indicates a potentially hazardous situation with moderate risk level which, if the warning is not obeyed, can cause death or serious injury.
	<b>CAUTION:</b> Indicates a potentially hazardous situation with a medium risk level which, if the caution is not obeyed, may cause minor or moderate injury or damage to the equipment.
	<b>Note:</b> Notes contain helpful suggestions or references to information not contained in the manual.

## 1.2 Save these instructions

This manual contains important instructions for Gresgying DC120kW/180kW Charging Station that need to be followed during installation, operation and maintenance of the unit.

### 1.3 **WARNING: Risk of electric shock**

- Switch off input power to your charging station before you install or service the charging station. Keep the power off until the charging station is fully installed with its covers secured.
- In the event of danger and/or an accident, a certified electrician must immediately disconnect the charging station from the electrical supply.
- Do not operate the charging station if it is physically damaged or if the charging cable has cracks, excessive wear, or other visible damage. Contact Gresgying or your distributor if you suspect that the charging station is damaged.
- Do not direct powerful jets of water toward or onto the charging station. Never operate it with wet hands. Do not put the EV charging plug into any liquid.
- Do not place fingers or other objects inside the charging port or plug port.
- Read the user instructions delivered with your Gresgying charging station and the User Manual for your electric vehicle before charging.

## 1.4 WARNING: Accumulation of gases

Some electric vehicles require an external ventilation system to prevent the accumulation of hazardous or explosive gases when charging indoors. Refer to your vehicle User Manual to check if your vehicle releases hazardous or explosive gases when charging.

## 1.5 CAUTION

- Use this charging station to charge compatible electric vehicles only. Refer to your vehicle user manual to check if your vehicle is compatible.
- This charging station may affect implanted electronic medical devices. Before you charge your vehicle, consult the supplier of the electronic medical device to determine if it can be affected by charging effects.
- This charging station contains no user-serviceable parts. The user must not attempt to service, repair, or relocate the charging station. Contact Gresgying or your distributor for more information.
- Make sure that the charging cable cannot be damaged (kinked, jammed, or driven over) and that the plug(s) do not come into contact with heat sources, dirt, or water.
- Only use the charging station under the specified operating conditions.
- Do not use explosives or flammable substances near the charging station.
- If you are unsure about how to use a charging station, ask for help.
- Do not allow children to operate a charging station. Adult supervision is required when children are near a charging station that is in use.
- Adapters, conversion adapters, or cord extensions must never be used on this charging station.

## 1.6 Charging station safety precautions



### CAUTION:

**Do not open the charging station doors when:**

- It is raining, snowing.
- The charging station is exposed to direct sunlight.
- Weather conditions are wet (fog, ...).

**Failure to follow these instructions can result in danger to the user and may void the warranty and liability.**



### CAUTION:

Electrostatic discharge.

This device contains components that can be damaged or destroyed by electrostatic discharge.

- When handling this device, observe the necessary safety measures regarding electrostatic discharge (ESD) according to EN61340-5-1 and 61340-5-2.

**CAUTION:**



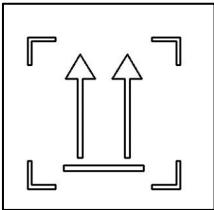

- This charging station must be stored and transported according to the specifications described in this manual.
- Even if the charging station can be used by a non-qualified person, the charging station may only be installed, commissioned, serviced, relocated, repaired and decommissioned by qualified persons. Failure to follow these instructions can result in danger to the user and may void the warranty and liability.
- Modification of the product is prohibited. It can result in danger to the user and may void the warranty and liability.
- This charging station contains no user-serviceable parts. The user must not attempt to service, repair, or relocate the charging station. Contact Gresgying or your distributor for more information.
- Make sure that the charging cable cannot be damaged (kinked, jammed, or driven over) and that the plug(s) do not come into contact with heat sources, dirt, or water.
- Only use the charging station under the specified operating conditions.
- Do not use explosives or flammable substances near the charging station.
- Do not use peripherals, consumables or accessories that do not conform or are unsuitable for the charging station.
- Do not use anti-graffiti treatment that may damage the charging station.
- Do not modify the features of the charging station (data settings, cabling, ...).
- This charging station must be protected against animals, object intrusion or water ingress even if they do not alter charging station operation.

**Failure to follow these instructions will result in damage to the charging station.**

## 1.7 Safety Labels on the packaging

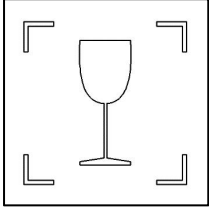
Label	Location	Description
	On the packaging	Caution The direction indicated by the arrow is upward;

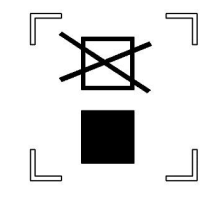

	On the packaging	<p>Caution</p> <p>The package contains fragile items, please handle with care;</p>
	On the packaging	<p>Caution</p> <p>Packaging and internal items shall be protected from rain and moisture.</p>
	On the packaging	<p>Caution</p> <p>Packaging is prohibited from stacking</p>
	On the packaging	<p>Warning</p> <p>Keep upright!</p>
	On the packaging	<p>Warning</p> <p>Handle with care</p>

## 2. Introduction

This Installation and User Manual outlines the installation requirements and steps for Gresgying DC120kW/180kW charging station, as well as how to use the station.

### 2.1 Important information

The document is produced for information purposes only and does not constitute an offer binding upon Gresgying. Gresgying has compiled the contents of this document to the best of its knowledge. No express or implied warranty is given for the completeness, accuracy, reliability, or fitness for particular purpose of its content and the products and services presented therein. Specifications and performance data contain average values within existing specification tolerances and are subject to change without prior notice. Prior to ordering, always contact Gresgying for the latest information and specification. Gresgying explicitly waives liability for any direct or indirect damage, in the broadest sense, arising from or related to the use and/or interpretation of this document. ©Gresgying. All rights reserved.

### 2.2 Scope of the Document

Keep this manual for the entire lifetime of the Gresgying DC120kW/180kW charging Station.



**CAUTION:**

This manual is intended as a resource for qualified personnel with experience in working on High Voltage projects who are capable of identifying the requirements and taking all necessary precautions to safely complete a Gresgying F3-EU installation.

© 2022 Gresgying Digital Technology Co., Ltd. - all rights reserved. No part of this document may be modified, reproduced, processed, or distributed in any form or by any means, without the prior written permission of Gresgying.

### 2.3 Product Introduction

Gresgylng DC 120kW/180kW EV charging station optimizes the use of space by charging up to two vehicles simultaneously using CCS2 and CHAdeMO.

Built-in dynamic power distribution technology that helps to improve equipment utilization.

User friendly design with clear SOC status indication, 7" touch screen, sunshade protection and cold light assistance.



## 2.4 Product Specification

Model				
Model Number	F3-EU			
Rated Power	120kW	180kW		
Input Parameters				
AC input voltage range	AC 380V (AC323V ~ AC437V)			
Frequency	45~65Hz			
AC input current range	194A (0~228A)	291A (0~342A)		
Grid types	TN-S			
Grid connection	3P+N+PE			
Output Parameters				
Output options	CCS2	CHAdEMO	CCS2	CHAdEMO
DC output voltage range	150V~1000V DC	150V~500V DC	150V~1000V DC	150V~500V DC
DC output current	0~200A	0~125A	0~200A	0~125A
Voltage Regulation Accuracy	≤±0.5%			
Current Regulation Accuracy	≤±1%			
Output Strategy	single output/ dual outputs			
Charging Type	Mode 4; Case C			
Power Limiting	Available			
Electrical Parameters				
Peak efficiency	≥95%			
Power factor (full load)	≥0.99			
THDi	≤5%			
Power Distribution	Yes			
Standby Power	≤75W			
Electrical Protection	Input Over/UnderVoltage Protection, Output Over Voltage Protection, Short-Circuit Protection, Over Current Protection			
Standard	IEC61851-1 / IEC62196-3			
User Interface & Control				
User authentication	APP, QR Code (optional), RFID			
HMI	7-inch touch LCD			
SOC State Display	Available			
Connectivity	Ethernet/4G (optional)			
Communication protocol	OCPP 1.6J			

## Mechanical Parameters

Cable length	4.5m	
Dimension(W*D*H)	800mmx600mmx1700mm	
Gross Weight	≤300kg	≤330kg
Protection	IP54, IK10	

## Environmental

Storage Temperature	-40 to 70°C ambient
Operating Temperature	-20 to 50°C ambient
Operating Humidity	5%~95% ( no condensation)
Altitude	≤2000m
Cooling Method	Forced Air Cooling
Noise	≤75dB

## 2.5 List of Tools



### CAUTION:

Some operations described in this manual may require a ladder or a stepladder.

Refer to your local regulation regarding the working height and relevant safety instructions.

Below is the list of the tools required (not included) to install the Gresgying DC120kW/180kW charging station:

- Iron crowbar
- Needle nose pliers
- Utility knife
- Phillips screwdriver
- M12\*100 expansion screw
- Percussion drill +  $\phi$  12 drill
- Afterburner lever
- 13# ratchet wrench
- 18# ratchet wrenchMCCB

The connecting point of the EV supply equipment shall be protected by an RCD having a rated residual operating current not exceeding 30 mA, RCD(s) protecting connecting points shall be at least type A, Rated voltage 400V, and a rated current of at least 250A for 120kW and a rated current of at least 350A for 180kW. You need to add AC molded case circuit breaker with leakage protection function in the front of single equipment .

## 3. Transport and Storage

### 3.1 Storage



**WARNING:**

Condensation inside the cabinet damages the charger.

- Only transport and store the charging station in its original packaging. No liability can be accepted for damage incurred when the product is transported in non-standard packaging.
- Store the charging station away from exposure to the sun and in a dry environment in the temperature range stated in the specifications.
- Disconnect input power before removing the charging station for storage or relocation.

**Failure to follow these instructions will result in waiver of warranty and product damage.**

### 3.2 Transport



**WARNING:**

Damaged product

After any transportation, make a detailed visual inspection of the charger with its packaging opened. Reject the product if there is any visible damage. Make all damage claims to the transport operator immediately and also immediately inform the sender regarding transport insurance.

Failure to follow these instructions can result in death, serious injury or equipment damage.

### Visual inspection

Check if:

- The exterior packaging has been damaged.
- The exterior panels of the charger are damaged (shock, scratch, ...).
- The doors are working properly.
- The interior of the charger is clean and undamaged

### 3.3 Packed Product Handling

#### Handling with a forklift

Handle the packed product with a forklift.

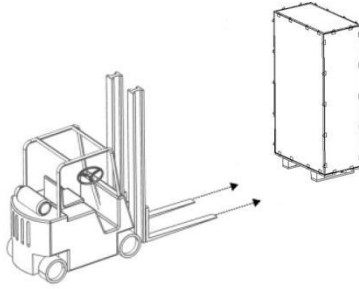

### 3.4 Packaging Removal



**CAUTION:**

Some operations described in this manual may require a ladder or a stepladder.  
Refer to your local regulation regarding the working height and relevant safety instructions.

1. Remove the metal clips that hold the wooden package.

Tools: needle-nose plier and an iron crowbar.

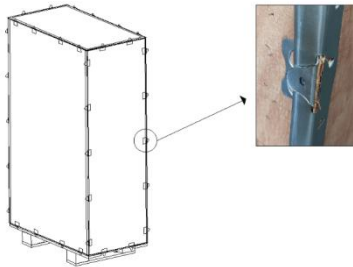

2. Put them aside.
3. Remove the roof cover

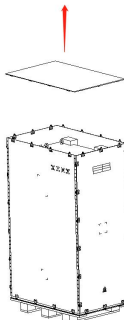

1. Remove the left and right side covers.

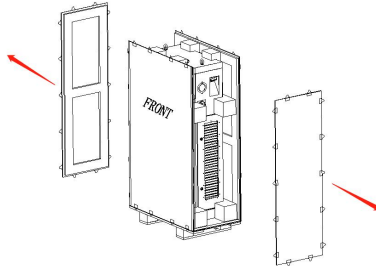

2. Remove the front and back covers.

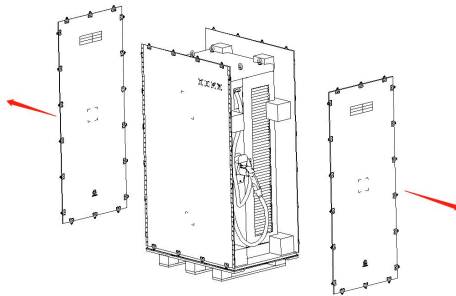

3. Remove the front and back covers.

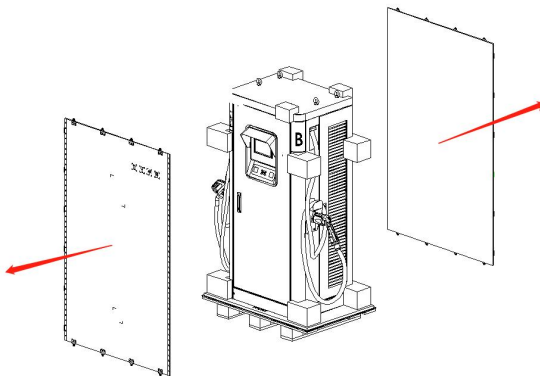



4. Remove the wrapping film wrapped around the cabinet.
5. Remove the PE plastic bag over the cabinet.
6. Remove the EPE cushioning blocks around the cabinet

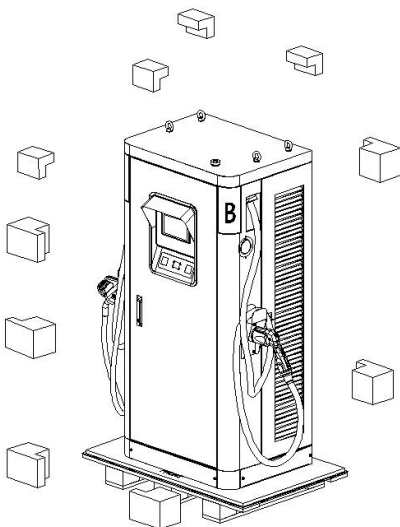

### 3.5 Supplied Components

The packaging includes the following components:

- Charging station
- Accessories

## 4. Product Handling

### 4.1 Handling with a forklift

The Gresgying F3-EU can be handled using a forklift.

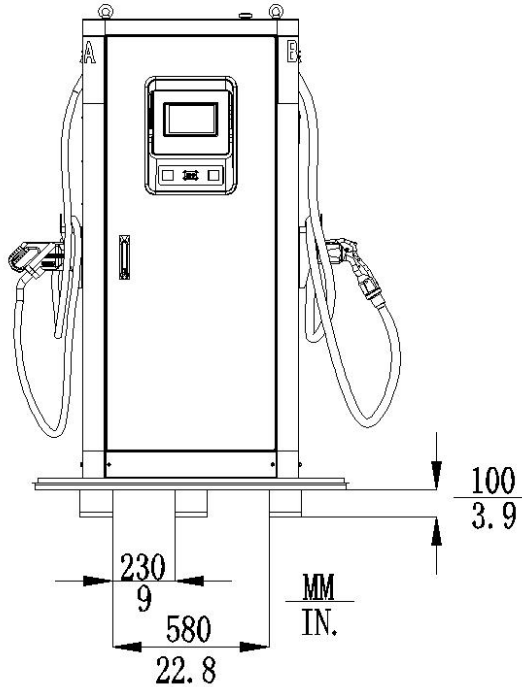

### 4.2 Handling by crane



**CAUTION:**

Some operations described in this manual may require a ladder or a stepladder.

Refer to your local regulation regarding the working height and relevant safety instructions.

The Gresgying F3-EU can be handled by a crane.

1. Install the hooks and slings:

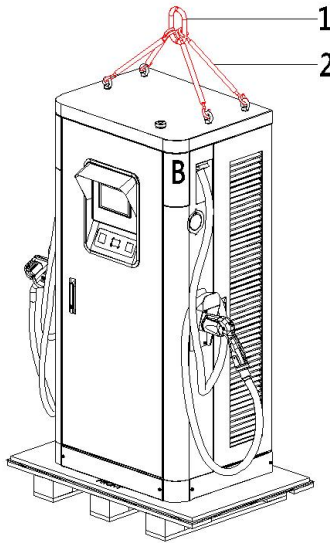

Item	Description
1	Lifting ring (not included)
2	Sling with 4 loops (not included)

2.



**CAUTION:**

Maintain the hoisting angle as below:

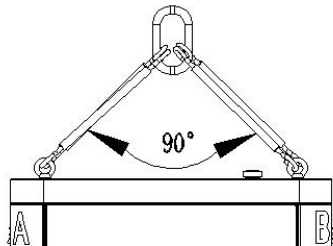
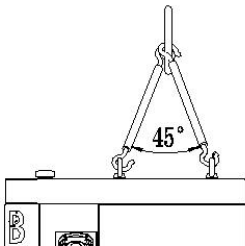

# 5. Product Features

## 5.1 Product Parts

Illustration	Description
 <p>The illustration shows a white electric vehicle charging station with a black base. It features a digital display at the top showing 'SOC% 88' and a 'B' logo. Below the display is a card terminal and a QR code. Two charging cables are attached to the front, one for CCS2 and one for CHAdeMO. A Z-shaped water proof shutter is located on the right side of the station. The station has a hummingbird logo on the front panel.</p>	<ol style="list-style-type: none"><li>1. SOC status display</li><li>2. Emergency stop button</li><li>3. 7" display screen</li><li>4. Card Terminal</li><li>5. QR code</li><li>6. Charging connector (left CCS2, right CHAdeMO, depending on the configuration)</li><li>7. Z shaped water proof shutter</li><li>8. Charge cable</li></ol>

Illustration	Description
	<ol style="list-style-type: none"> <li>1. Transparent protective cover</li> <li>2. Circuit breaker</li> <li>3. Metal sheet protective cover</li> </ol>

## 5.2 Nameplate

The nameplate is located at the bottom of the left door.

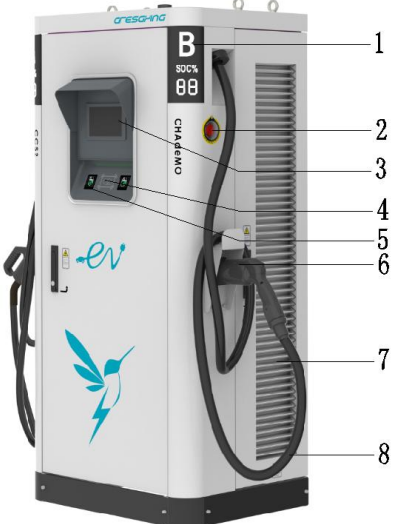
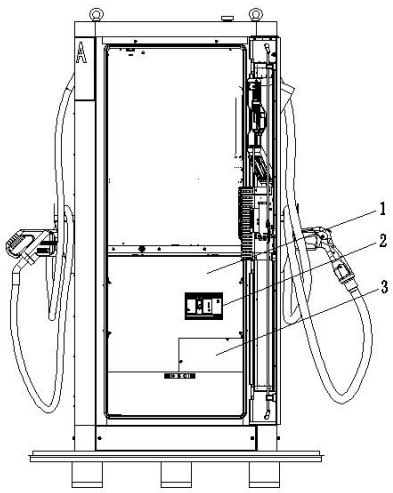
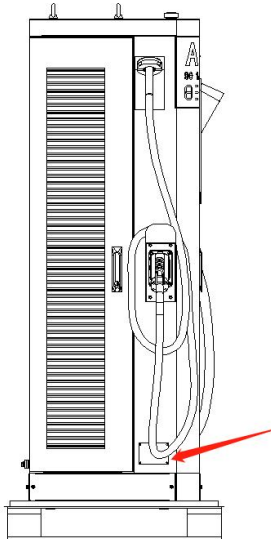

## Nameplate

## Description

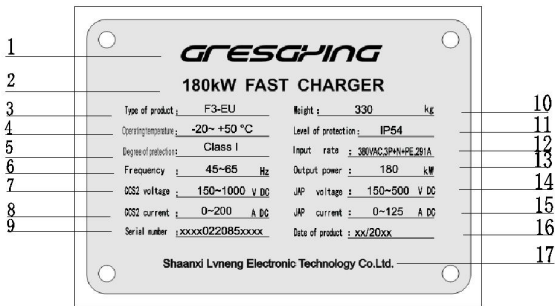
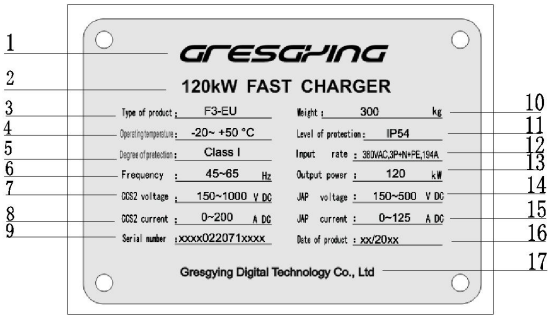

1. Manufacturer logo
2. Product description
3. Model number
4. Operating temperature
5. Degree of protection
6. Frequency
7. CCS2 voltage
8. CCS2 current
9. Serial number
10. Weight
11. IP protection
12. Input voltage
13. Output power
14. CHAdeMO voltage
15. CHAdeMO current
16. Production date
17. Manufacturer

## 6. Preparation for Installation

The following recommendations are intended as a guide to help you prepare for the installation of the Gresgying DC120kW/180kW charging station.

### 6.1 Safety precautions

You must read and observe the Safety instructions on page 5 at the beginning of this manual before you install, service, or use the Gresgying DC120kW/180kW charging station. The installer must ensure that the charging station is installed in accordance with the relevant country-specific standards and local regulations.

### 6.2 Plan installation

- Calculate the existing electrical load to determine the maximum operating current for the charging station installation.
- Calculate the distance from the local power supply panel to the charging station installation to find the voltage drop. Local regulations may apply and can vary depending upon the region or country.
- Obtain all necessary permits from the local authority that has jurisdiction.
- PE grounding connectors must be not spliced.
- Refer to local regulations, maximum current and voltage drop to select the conductor sizes.
- Use the correct tools and ensure sufficient material resources and protection measures.
- Make sure that there is good cellular reception where the charging station will be installed.
- Prepare the installation areas with the correct power wiring and data cabling.
- Prepare the upstream electric switchboard according to local regulations and the Gresgying recommendations in Upstream requirements on page 27.

### Ethernet network

To connect several Gresgying DC120kW/180kW charging station (for network sharing), it is necessary to install an Ethernet network.

### 6.3 Select location

The charger is intended for outdoor or indoor areas.

Position the charging station, where possible, in surroundings where it is not exposed to extreme sunlight and vulnerable to external damage.

The charger is intended for location in a non-restricted area.



**Note:**

In locations with harsh weather conditions (high temperatures, snow, strong sun conditions,...), it is recommended to ensure additional protection such as canopy or roof protection.

## 6.4 Parking space placement

To achieve the maximum cable length, it is recommended to place the Gresgying F3-EU as described below.



**Note:**

Leave adequate free space in front of the charging station to ensure that users can interact with the touchscreen and other interfaces safely and comfortably.



**Note:**

Leave at least 600 mm on both side of the charger in order to ensure the connector is accessible.

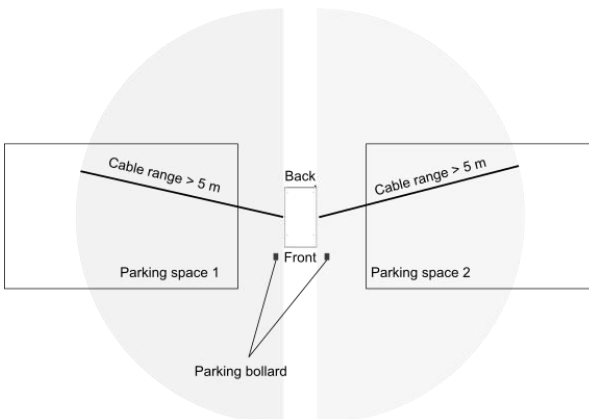
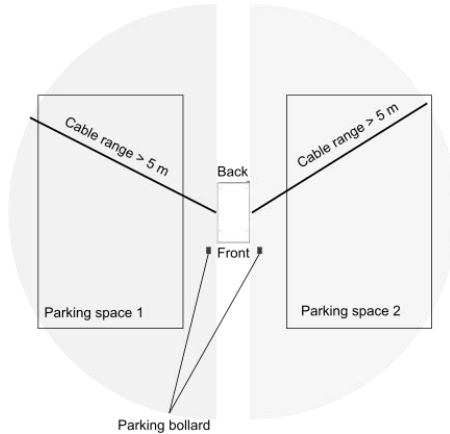



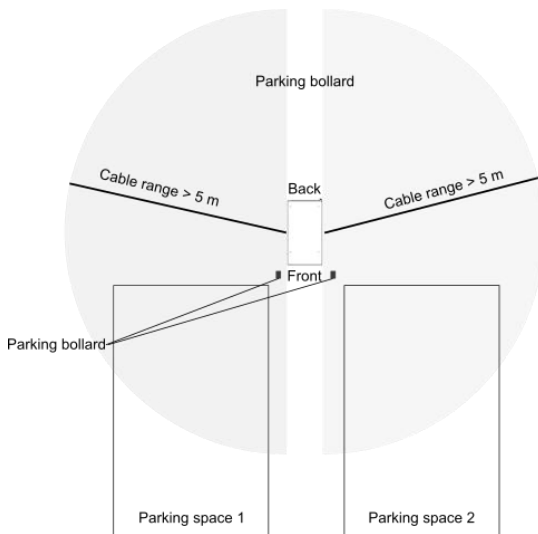

**Note:**

Bollards should not interfere with the clearance around the charger.

## 6.5 Cooling

The air inlet is located on the right door of the cabinet, and the air outlet is located on the left door of the cabinet. The ventilation in the cabinet must meet the requirements of 1400 m<sup>3</sup>/h.

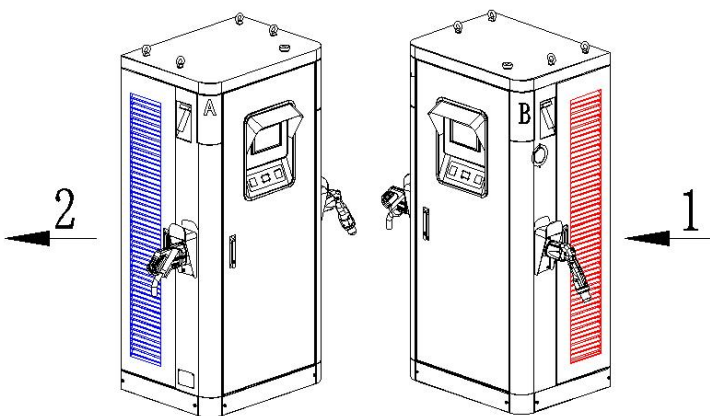

1. Air inlet; 2. Air outlet

## 6.6 Clearance

The Gresgying F3-EU requires the following space for cable handling by users and for maintenance operations.

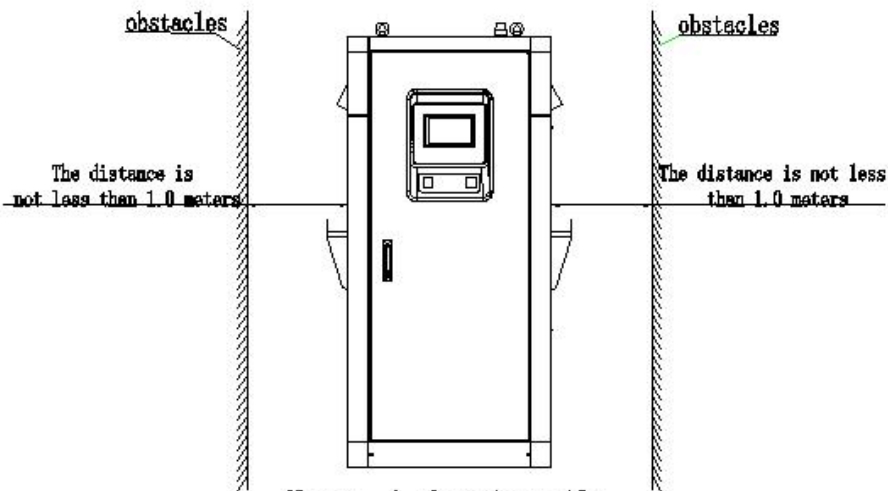

Notes: A charging pile

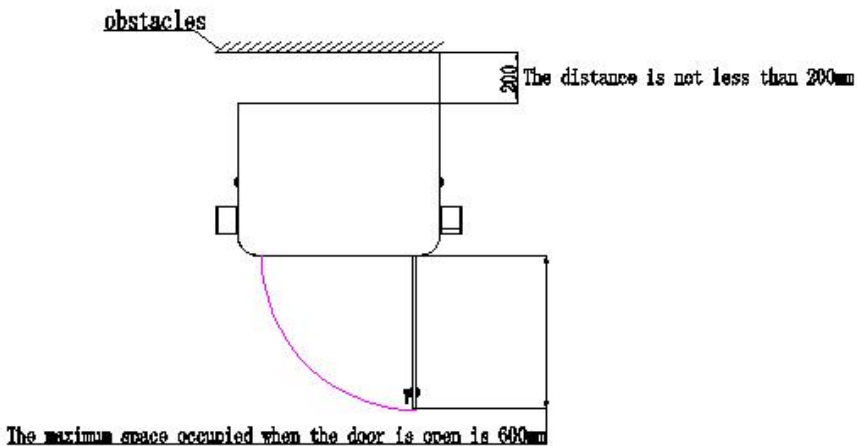

Notes: The distance between the front door and an obstacle is at least 0.6 m

## 6.7 Foundations

- Observe the following rules regarding the foundations:
- Foundations must be carried out in accordance with local regulations.
- Concrete characteristics must be calculated based on the technical data of the charging station.
- The concrete should be frost-proof.
- Thickness of the foundations must be calculated in accordance with the weight of the system and the installation site.
- The foundation must be flat and leveled.
- A slope deviation to the left/right or front/back may cause infiltration of water and damage the charging station.
- Foundations must be under the ground.
- Charger must be installed on the ground.

## 6.8. Implantation plan

Prepare the foundations according to the diagram below:

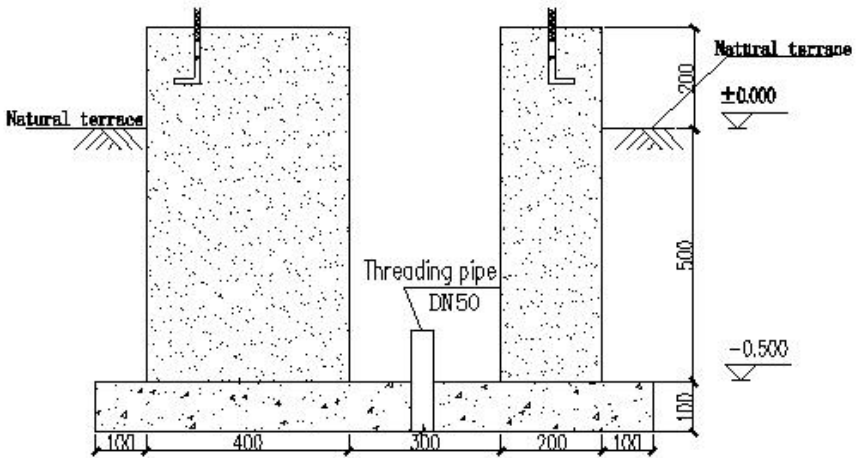
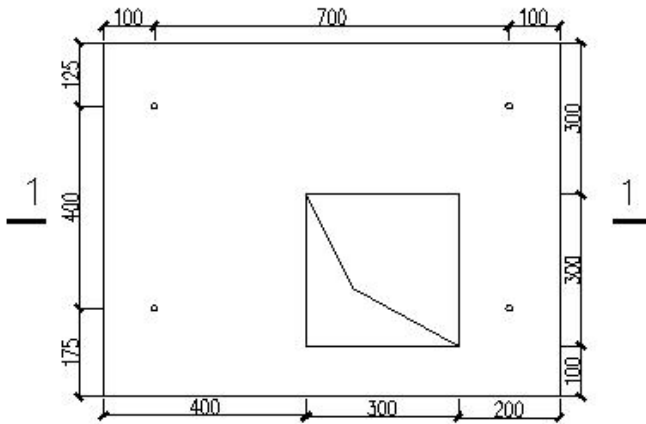

**1-1**

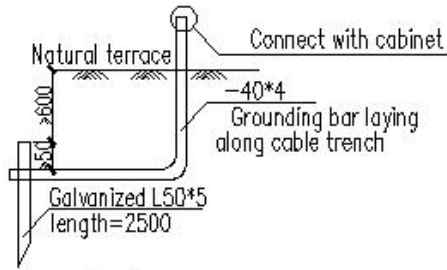

**Grounding diagram**

## 6.9 Route power supply cables

Prepare the cable and use standardized cable only. For AC cable, we suggest using RVVZ cable which can stand on over 70°C, 120kw cabinet cable size is 600V/1000V-ZA-RVV-3\*95+2\*50mm<sup>2</sup>-outdoor cable-CE, 180kw cabinet cable size is 600V/1000V-ZA-RVV-3\*185+2\*95mm<sup>2</sup>-outdoor cable-CE.

## 6.10 Protection against electric shock and short circuits

### Protection against electric shock

The charging station contains the following devices to protect against electric shock:

- IMD (Insulation Monitoring Device). One on each outlet on CHAdeMO and CCS2.
- RCD (Residual Current Device) on 12 Vdc power supply
- Surge protector
- MCCB for AC Input

The following device is not included in the unit and must be installed in the switchboard upstream:

- Refer to local regulations, maximum current and voltage drop to select the device against electric shock in switchboard upstream.

### Short circuit protection

The charging station contains the following devices to protect against short circuit:

- CCS2 and CHAdeMO outlet is protected by fuse.

## 6.11 Electrical requirements

### 6.11.1 Upstream requirements

Charging station

Electrical connection must be carried out by a professional electrician according to the local regulations.

Charging station must be connected to an electrical network with the following characteristics:

- 3 Phases (3P + PE +N\*) (\*Neutral required in case of AC socket).
- 380 Vac +/- 10%
- 50/60 Hz

The main switch disconnecter, located upstream of the charger power supply, must be rated by the installer.

Refer to local regulations, maximum current and voltage drop to select the upstream protection.

**Note:**

A RCD 30mA type A is required as minimum.

## 6.11.2 Grounding Instructions

Observe the following rules for the grounding instructions:

- Ground impedance must be lower than 20 ohms in dry conditions where the charging station is installed.

## 7. Install the Gresgying F3-EU

### 7.1 Handling

**WARNING:**

- Always transport the charger in an upright position.
- Do not manipulate the charger when it is connected to the power supply.
- Do not use a crane type hoist that is unable to support the weight of the charger.
- The center of gravity of the charger is high, take care when handling.
- Do not place your hand underneath the charger or inside the feet through the side openings.
- The charger must be protected against overturning. This protection must be maintained until final mounting.

### 7.2. Open the door of the Gresgying F3-EU

**CAUTION:**

When opening the door, please follow the instruction next to the door lock.

**Failure to follow this instruction will result in visible damage to the product.**

Tool: Door Key

Locate the handle.

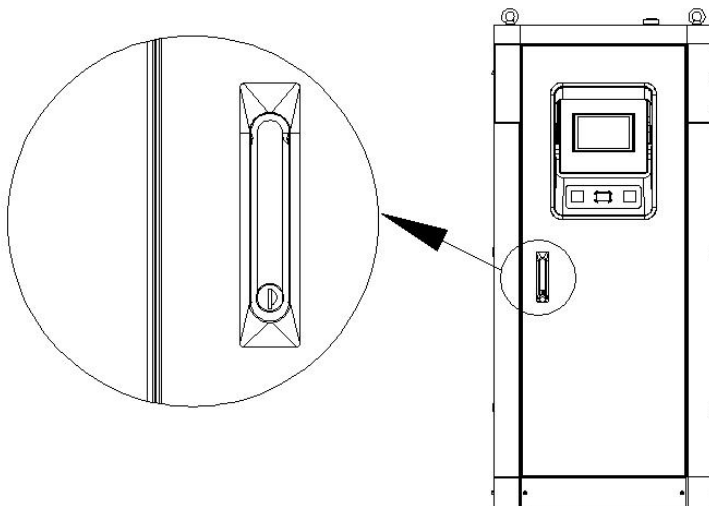

### Open the door

1. Use the key to open the lock.
2. Pull out the handle
3. Rotate the handle counterclockwise
4. Open the door

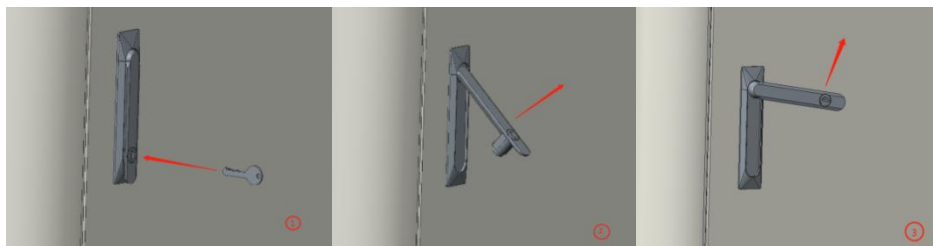

### 7.3 Remove the lower plastic cover

Tool: Phillips screwdriver

1. Locate the lower plastic cover.

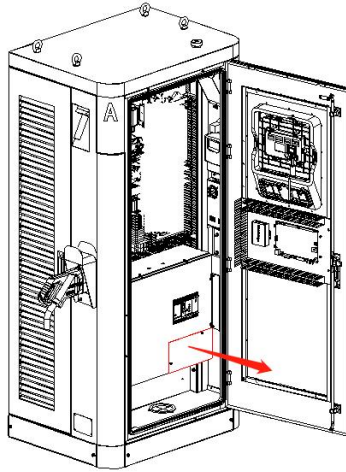

2. Loosen the 3pcs M4 nuts that hold the plastic cover.

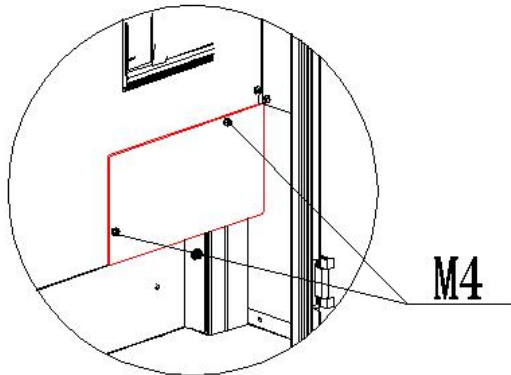

3. Remove the plastic cover.



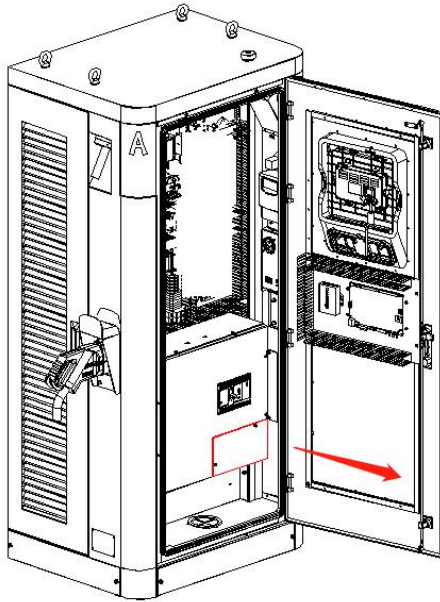

**Note:**

Please install it in the original position after completing the wiring

## 7.4 Remove the left and right plinth and the wooden pallet

Tool: Phillips screwdriver

1. Locate the left and right plinth.

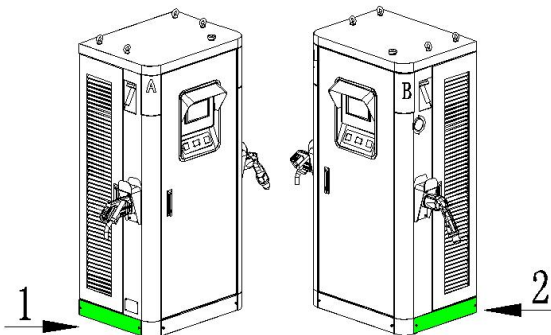

1. Left plinth; 2. right plinth.

2. Loosen 2pcs M6 nuts on each side.

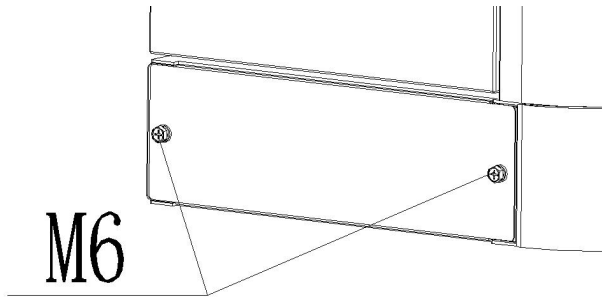

3. Remove the left and right plinth.

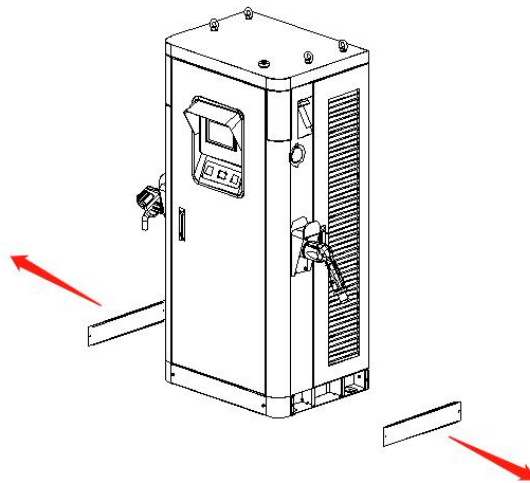

4. Remove the 4 M12 nuts (fixing the wooden pallet) and spacers on both sides.

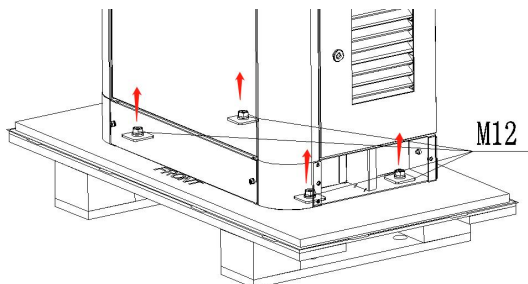

5. Remove the wooden pallet.

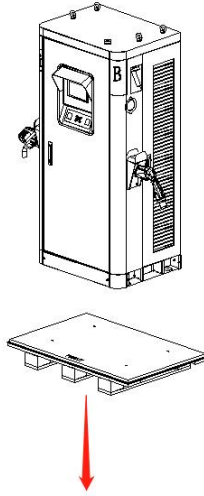

## 7.5 Placing

When the installation area is prepared, you can install and connect the charging station.

1. Use a crane to hoist the charging station and place it on the treated foundation, make sure that the  $\varnothing 15$  mounting hole reserved on the charging station is aligned with the M12 expansion bolt on the foundation, and tighten it with a wrench;

After the cabinet is installed, shake the cabinet from different directions, and you should not feel any obvious looseness or shaking.

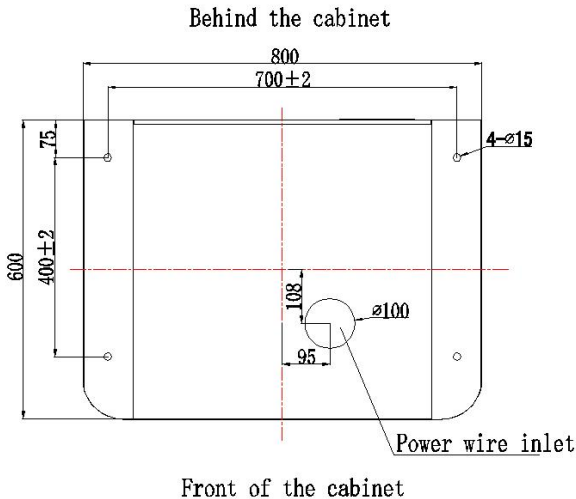

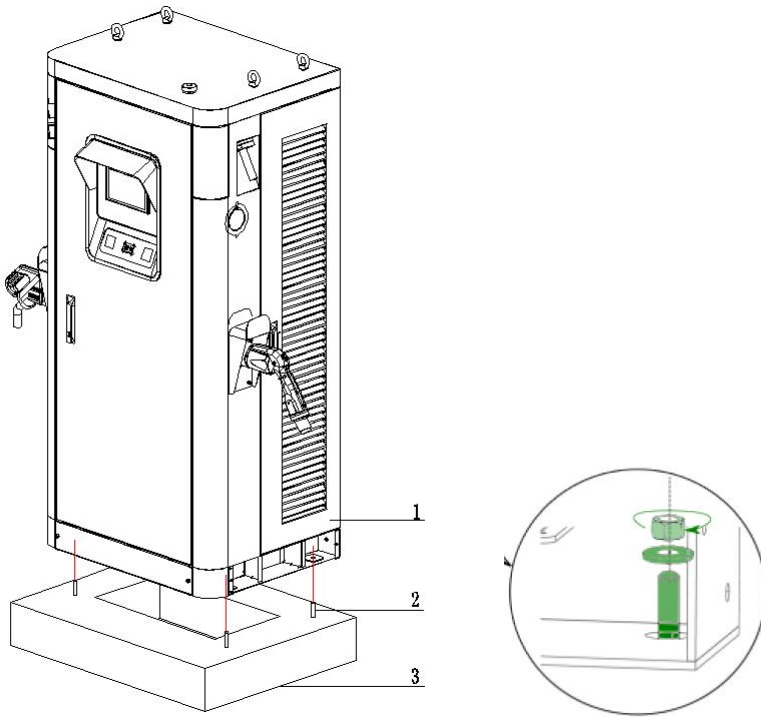

1. charging station; 2. expansion bolt; 3. foundation

2. Install the left and right plinth at the bottom of the charging station.

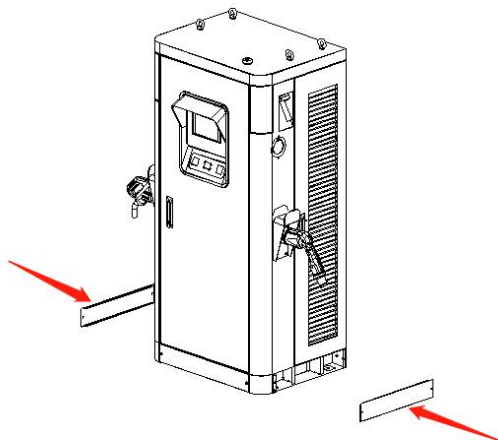

## 7.6 Electrical Connections

### Cable connection

1. Open the front door.
2. Take live lines, neutral line and earth line from outside to inside through protecting holes on the bottom of equipment cabinet.
3. Connect earth line to PE strip. Connect 3 live lines and 1 neutral line to L1\L2\L3\N screws. Follow the instruction as showing below.
4. Sealing the protecting holes to prevent the enter of foreign matter by using fireproofing mud.

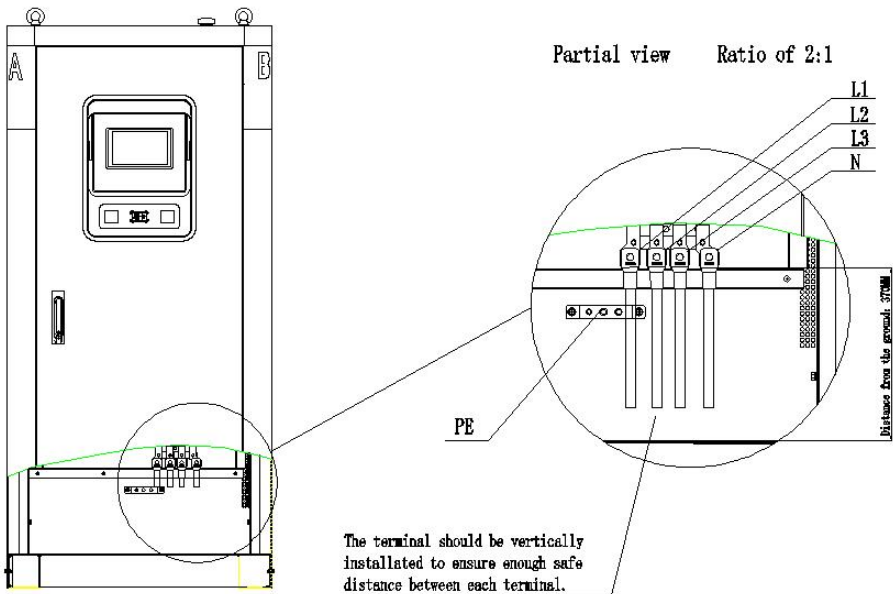

## 8. Commissioning

Danger: Risk of Electric Shock



### **DANGER:**

Risk of electric shock.

Before servicing, switch off the power at the main breaker (outside of the breaker) and switch off MCCB in AC power supply system



### **WARNING:**

Hazardous voltages

Before servicing:

Electrical charge may be stored for up to 5 min after switching off!

Discharge and make sure it is voltage-free.



### **Note:**

The unit must be properly assembled in accordance with the assembly instructions.

## Operation of power on the charging station

During operation, pay attention to the danger of high voltage to avoid personal injury and property damage. The system must be well grounded before power-on. An installation check must be carried out before commissioning. Confirm that the main AC input switch Q1 and circuit breakers Q3 and Q4 are disconnected, and the charging gun head is on the cabinet body, and ensure that all devices are installed in place.

### 8.1 Preparation for Power on

Make sure that the upstream power supply switch of the charging system is disconnected;

Use a multimeter to confirm that there is no short circuit between the AC input L1\L2\L3\N\PE;

Use a multimeter to measure and confirm that there is no short circuit between DC+\DC-\PE of the two charging gun heads;

Connect the upstream power supply switch of the system;

Use a multimeter to measure that the three-phase input power supply voltage in the charging system cabinet is within the allowable working voltage range of the system (323VAC ~ 437VAC).

### 8.2 power on the charging station

Connect the AC input general MCCB Q1 of the charging system;

Connect the circuit breakers Q3 and Q4 of the front cabinet door of the charging system, and close the front door and the left and right doors;

After 2S, the system will automatically pull in the AC input contactor after the system self-check is normal, and the power module is electrified.

## 9. Use of the Gresgying F3-EU

The charger can be used by ordinary people (no special qualification or training is needed).

The owner of the charging station shall provide to the customer with all the procedure, security and warning related information.



### **WARNING:**

Risk of electric shock:

- Do not operate the charging station if it is physically damaged or if the charging cable has cracks, excessive wear, or other visible damage. Contact Gresgying or your distributor if you suspect that the charging station is damaged.
- Do not direct powerful jets of water toward or onto the charging station. Never operate it with wet hands. Do not put the EV charging plug into any liquid.
- Do not place fingers or other objects inside the charging port or plug port.
- Read the user instructions supplied with your Gresgying charging station and the User Manual for your electric vehicle before charging.
- Make sure that the charging cable cannot become damaged (kinked, jammed, or driven over) and that the plug(s) do not come into contact with heat sources, dirt, or water.
- When the cable is connected on the charging station, do not leave the cable lying around on the floor.

## 9.1 Start Charging

Take off the connector and connect it to the vehicle.

Click on "Available" to confirm the the vehicle is connected to the charging point.

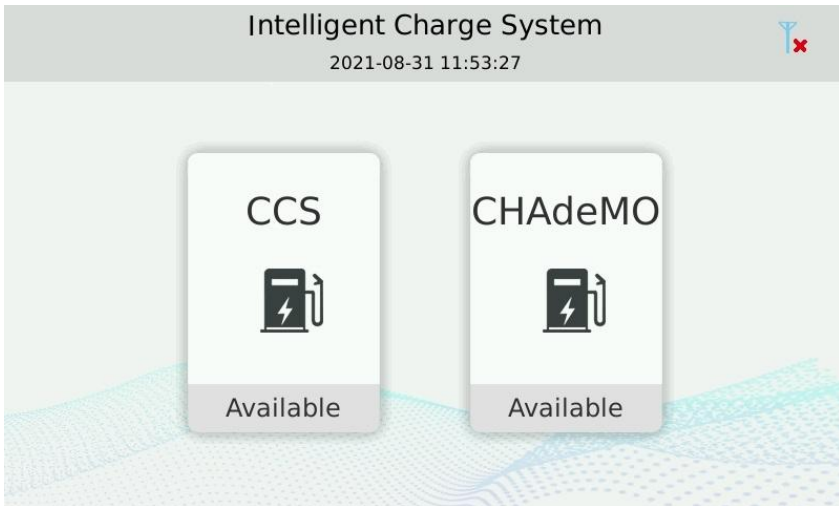

Click on "Confirm".it display as follow:



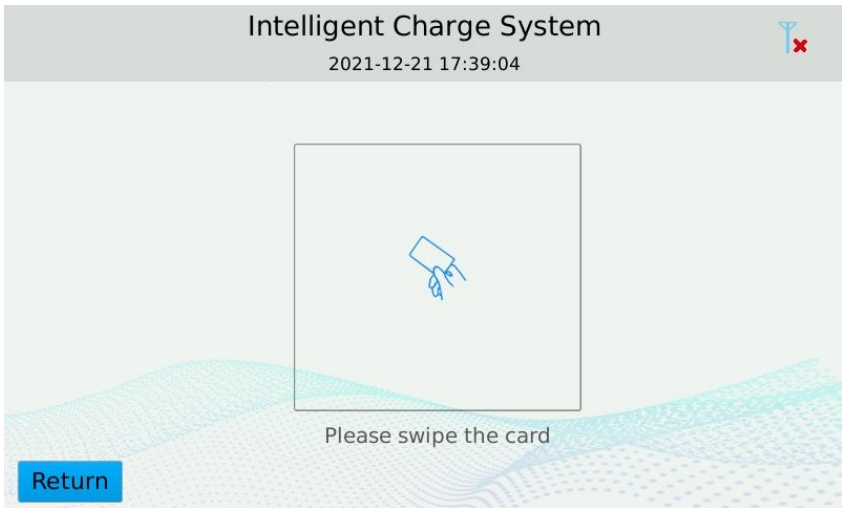

Swipe the RFID card to start charging, and the screen shows:

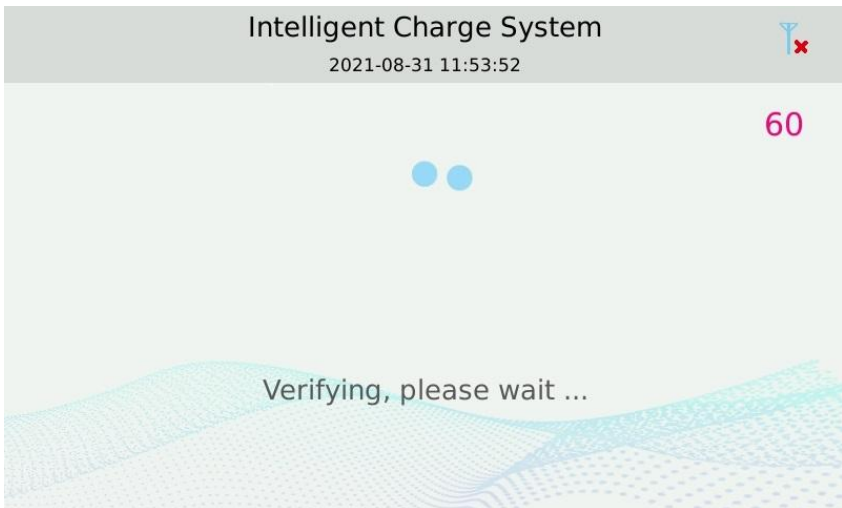

After verification is successful, it will display:

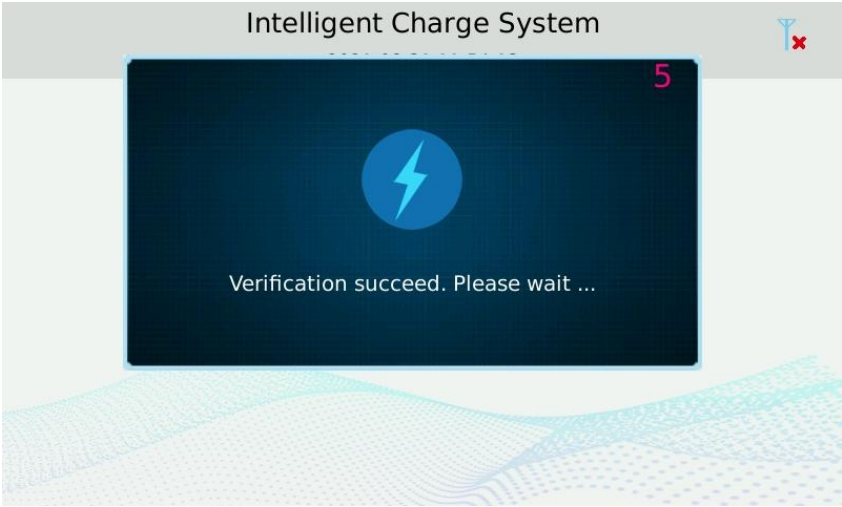

The charging station starts to charge the vehicle

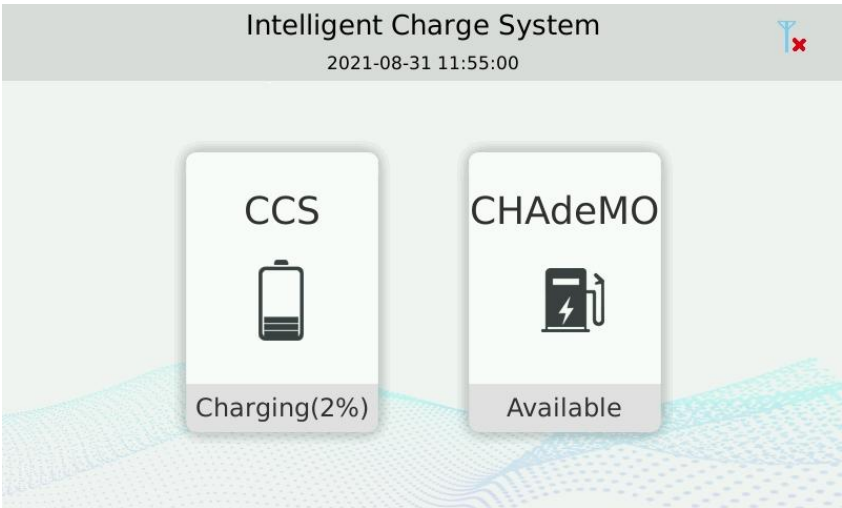

## 9.2 Stop charging

Click on the charging button.

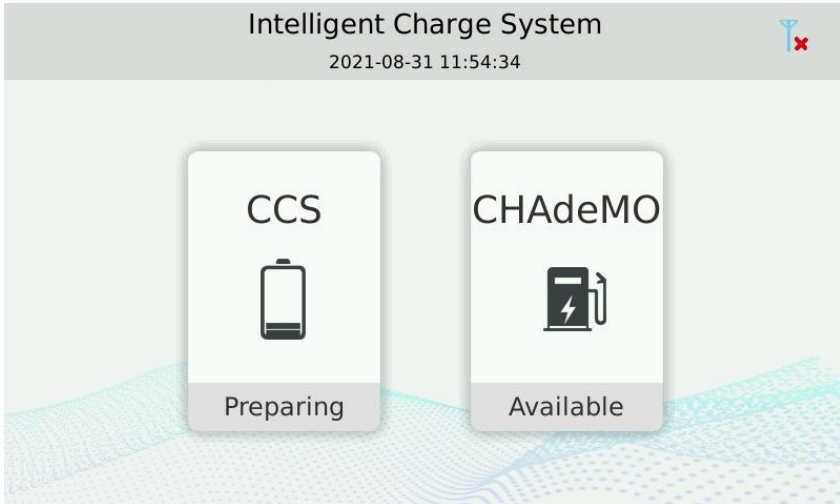

The charging information pops out and swipe the card again to stop charging process.

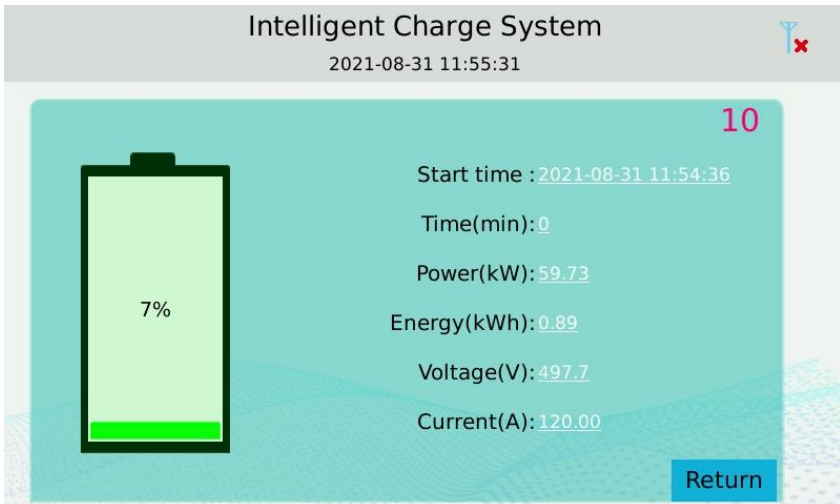

Stop charging. Please wait.



The screen returns to main menu and shows charging finished.

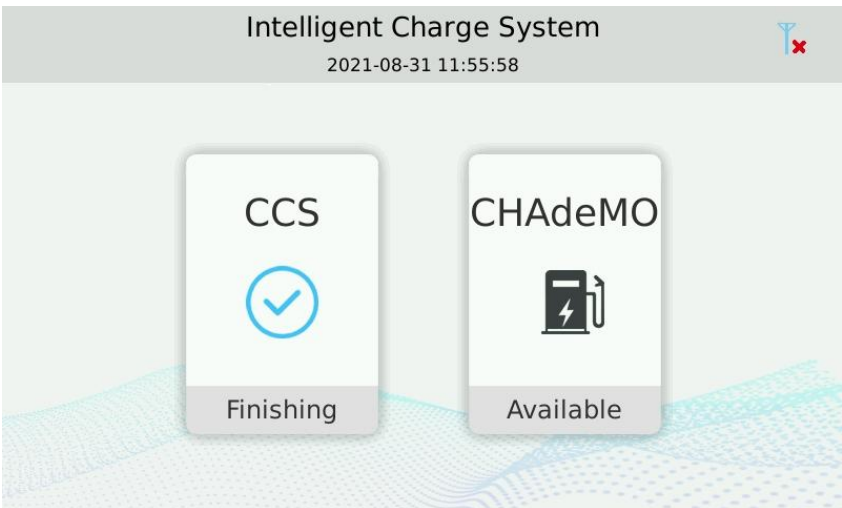

To check the information of charging, you may click the "Completed" button and scan them.

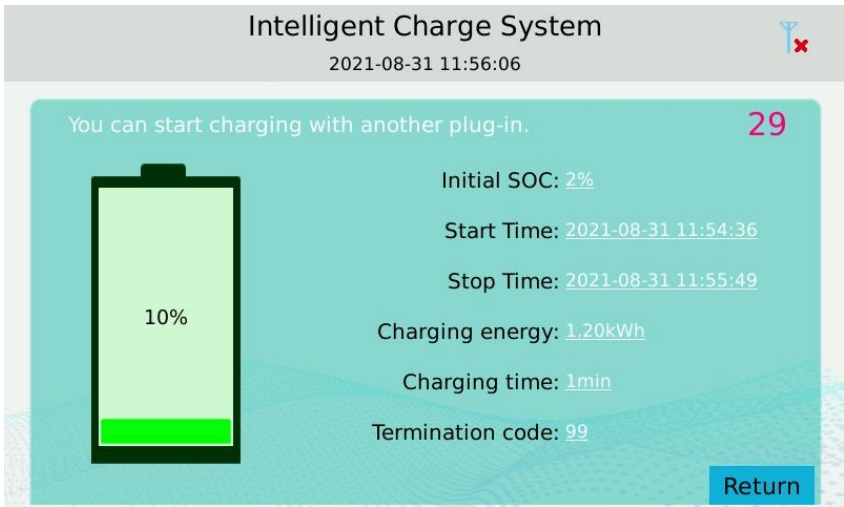

Put back the connector to its origin position after charging.

### 9.3 Charging by online or offline

The default charging mode of the charging station is offline. Under the offline function, you can use the M1 card to start the device; online function can use 4G communication method .

The specific operations are as follows:

Click on the blank space at the upper left of the screen, the login interface appears, enter the password '301204', click 'Enter', and click 'Login' to enter the settings main interface.

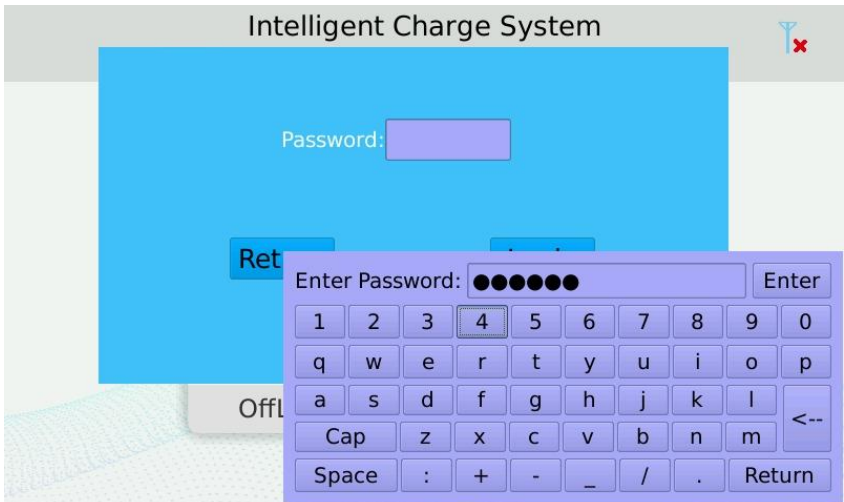

Click 'Charge Setting', select online or offline in 'Authorize Mode', click 'Save' and wait for 45 / 53

the device to restart.

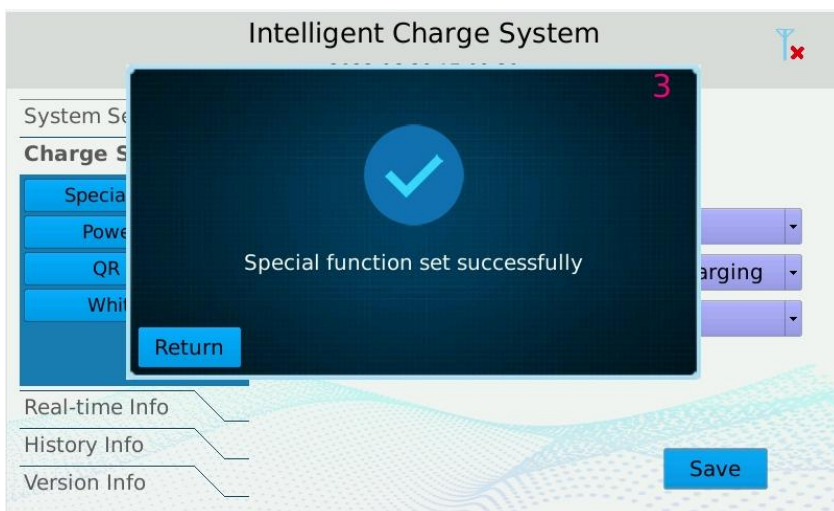
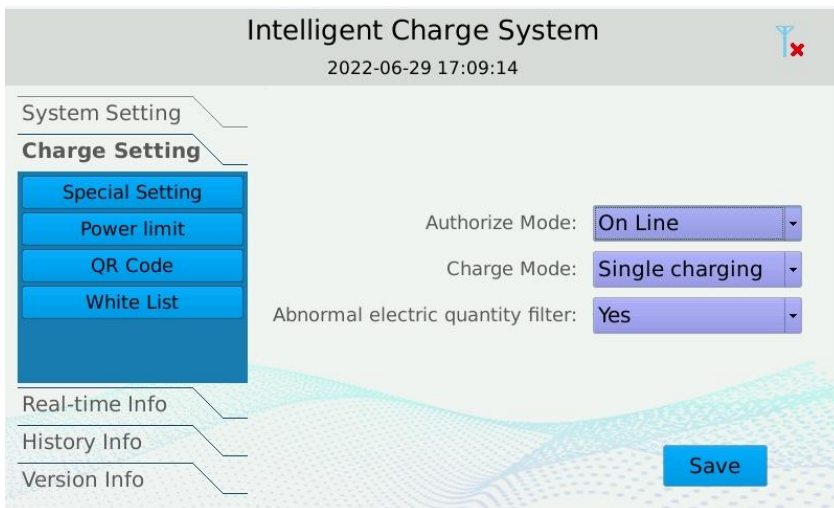

After restarting, Click on the blank space at the upper left of the screen, the login interface appears, enter the password '301204', click 'Enter', and click 'Login' to enter the settings main interface again.

Click "System Setting", click "CSCU setting", input the station number provided by the platform (if any), input the Platform Address of the platform. Click "Save", the TCU set successfully and wait for the device to restart.

# Intelligent Charge System

2022-06-29 16:55:02

**System Setting**

- CSCU Setting
- DC Setting
- Time Setting
- Login Password
- Set Password
- APN Setting

Charge Setting

Real-time Info

History Info

Version Info

IP:

Gateway:

DNS Server:

Station:

Platform Address:

**Save**

# Intelligent Charge System

**System Setting**

- CSCU Setting
- DC Setting
- Time Setting
- Login Password
- Set Password
- APN Setting

Charge Setting

Real-time Info

History Info

Version Info

**Return**

**Save**

8

TCU set successfully  
The system is restarting, please wait!

## 10. SOC Display

The two SOC Displays corresponds to the two guns A and B in the charging system.

When the gun is not connected to a vehicle, it displays the current BMS auxiliary source voltage, such as "12";

When the gun is connected to a vehicle, it displays "CC";

In the process of starting the charging , it flashes to display "CC";

During the charging process, it flashes to display the current battery power value;

When there is a general fault in the charging system, it displays "Er", and when the system has a specified fault, it displays "E0" ~E9".

<b>SOC Display</b>	<b>Fault type</b>
Er	General fault
E0	Emergency stop fault
E1	poor network signal
E2	BMS auxiliary source fault
E3	Charger insulation fault
E4	BMS communication failure in identification phase
E5	System fan failure
E6	Start-up charge failures caused by electric vehicles
E7	Module slot does not match
E8	The module address is out of range or the module address is duplicated
E9	Communication failure between rectifier box and terminal or communication failure between rectifier box and display control



# 11. Decommissioning

Remove and dispose of the charging station in accordance with applicable local disposal regulations.





## **DANGER: Risk of electric shock**

Before the charging station is removed, switch off all power at the power supply cabinet. Secure the power supply cabinet and put up warning signs to prevent accidental supply of power.

To remove the Gresgyng F3-EU charging station, follow the installation steps listed above in reverse order.

Dispose of the charging station in a responsible manner.

	<p>Do not dispose of this charging station in household waste. Instead, dispose of this charging station at a local collection point for electric/electronic devices in order to enable recycling and thus avoid negative and hazardous environmental impact. Ask your city or local authorities for the address of your local facility.</p>
	<p>Recycling materials saves raw materials and energy, making a major contribution to conservation of the environment.</p>

## 12. Preventive Maintenance

For safe operation of the charger and to ensure a continuous and adequate level of service for users, regular maintenance and control of the equipment is required.

In addition to these regular maintenance operations, in case a fault or suspected fault, a corrective maintenance operation must be performed.

Below is the recommended preventive maintenance plan. If the operating environment is harsh (such as sandy environment, dusty environment, etc.), please shorten the maintenance cycle as appropriate.

Item	Period	Action
Air inlet filter	Every month	Clean
Cooling fan	Every 6 months	Check and repair/replace if damaged
Power module fan	Every 6 months	Check and repair/replace if damaged
Power module	Every 3 months	Check and repair/replace if damaged
Charge cable	Every 6 months	Check and repair/replace if damaged
Cabinet appearance	Every 6 months	Check and repair/replace if damaged
Main control board	Every 6 months	Check and repair/replace if damaged
Display control board	Every 6 months	Check and repair/replace if damaged
Emergency stop switch	Every 6 months	Check and repair/replace if damaged
Display screen	Every 6 months	Check and repair/replace if damaged

### Accident handling

Catastrophic accidents include charging equipment failures caused by lightning strikes, flooding, earthquakes, fires and other disasters. For disasters that may seriously affect safety, prevention should be the priority. At the same time, the charging station should have countermeasures and corresponding manpower and material resources to deal with these disasters, and should have emergency management regulations and major accident repair procedures.

It is recommended that when there is water immersion near the charging device, all switches inside the charging station should be disconnected, and the upstream power supply switch of the charging station should be disconnected to ensure the safety of personnel and prevent electric shock. The power module can be pulled out to minimize losses.

## 13. Troubleshooting

Fault	Analyze	Troubleshooting
AC contactor not contacting	Emergency stop button was pressed	Rotate and reset the emergency stop button
	The monitoring system detected there was a fault in the system and forced it to be disconnected	Find out the system fault
Ambient light off	Ambient light board failure	Replace the ambient light board
SOC Display does not display or displays abnormally	SOC Display failure	Replace SOC assembly
Cannot start charging	The input and output terminals of the charging module are not plugged in	Insert the charging module into place
	The charging gun not connected to the vehicle	Connect the charge cable to the vehicle and then start
	Cabinet door not closed	Restart after closing the cabinet door
	charging voltage mismatch	Please confirm whether the battery charging demand voltage matches the maximum output voltage of the charging station
	BMS auxiliary source voltage mismatch	Confirm that the BMS demand voltage of the charging equipment is consistent with the output BMS voltage of the charging station
	system error	Please check the fault code information and try again after troubleshooting
	Damaged charging module	Replace the charging module
	No charging modules in the charging station	Install the charging module
	Faulty	Check the communication cable

	communication cable of the charging module	of the charging module
	Damaged output DC contactor	Replacing the DC Contactor
	DC fuse blows	Replace DC fuse; check DC output for short circuit fault
	Lightning arrester damage	Replacing the SPD
	SPD fault alarm signal	Check whether the lightning protection fault alarm cable is properly connected
	Damaged electricity meter	Replace the meter
	Monitoring unit failure	Replace the monitoring unit
	The communication cable between the master and slave monitoring units is faulty	Check whether the communication cable connection between the two monitoring units is normal
	The front door or the left and right doors are not closed	Check whether the fault disappears after the front door or the left and right doors are closed
	The insulation of the positive or negative output of the charge gun and the ground is reduced	Use a multimeter to measure whether the impedance between the positive and negative poles of the DC output to PE is greater than 40K. If it is lower than this value, please troubleshoot or replace the charge cable.
	System cooling fan failure	Maintain or replace the system cooling fan
	System temperature over protection	Check whether the air inlet and outlet of the system are blocked

Note: When the high-voltage power distribution of the upstream transformer of the charging equipment is cut off, the MCCB Q1 in the charging equipment should be disconnected immediately to prevent the voltage shock causing damage to the charging equipment after the high-voltage power distribution of the upstream transformer is restored. damage. Please wait for the high voltage distribution of the upstream transformer to be restored before restoring the power supply to the charging equipment

