

### 物料输送系统说明:

1. 物料通过双工位吨包、小包站投入指定的物料储存罐中，配备快拆接头，接头时间小于三分钟。
2. 物料通过系统控制负压罗茨风机输入至指定的挤出机中，每种物料单料单管，确保每台挤出机可同时生产不同产品。
3. 挤出机上游收料桶配备双通道，当生产有余料或需换料时可由备用通道输出。
4. 五台挤出机采用集中除尘的方式
5. 系统通过PLC控制，配备中控系统，可实时监控物料的走向及生产情况

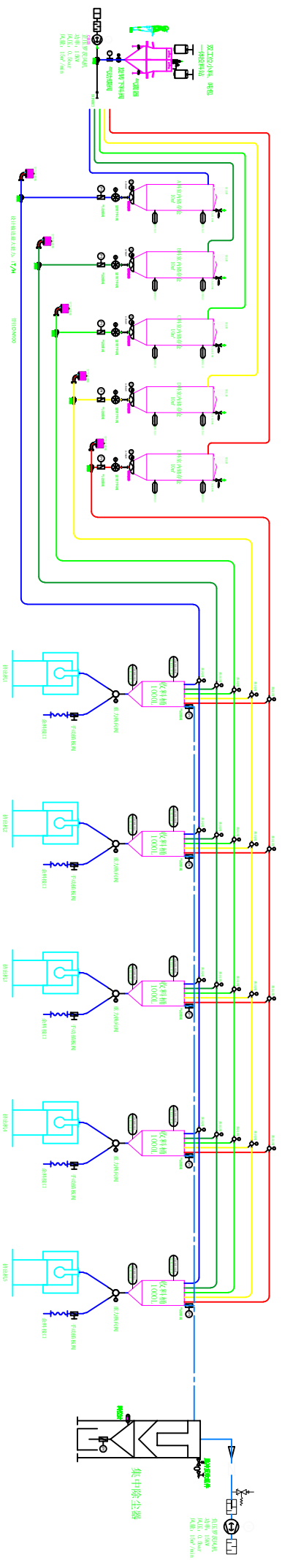

物料特性表 (客户提供数据)

物料名称 堆积密度 安息角

**系统简介:**  
系统设计按可靠，节能为原则，罐体国内制作，按照欧洲标准设计检验。自动化控制系统采用西门子S7 1200组建。客户端使用11英寸触摸屏，手动CALL料或根据配方自动送料。

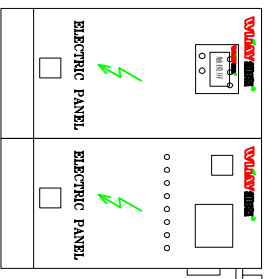

Legend	Supplier
Blue line	supplied by Weiest
Green line	supplied by Weiest
Yellow line	supplied by Weiest
Red line	supplied by Weiest
Purple line	supplied by Weiest
Orange line	option
Light blue line	supplied by customer

维杰供货		选项设备	
NO.1	NO.2	NO.3	NO.4
NO.5	NO.6	NO.7	NO.8
NO.9	NO.10	NO.11	NO.12
NO.13	NO.14	NO.15	NO.16
NO.17	NO.18	NO.19	NO.20
NO.21	NO.22	NO.23	NO.24
NO.25	NO.26	NO.27	NO.28
NO.29	NO.30	NO.31	NO.32
NO.33	NO.34	NO.35	NO.36
NO.37	NO.38	NO.39	NO.40
NO.41	NO.42	NO.43	NO.44
NO.45	NO.46	NO.47	NO.48
NO.49	NO.50	NO.51	NO.52
NO.53	NO.54	NO.55	NO.56
NO.57	NO.58	NO.59	NO.60
NO.61	NO.62	NO.63	NO.64
NO.65	NO.66	NO.67	NO.68
NO.69	NO.70	NO.71	NO.72
NO.73	NO.74	NO.75	NO.76
NO.77	NO.78	NO.79	NO.80
NO.81	NO.82	NO.83	NO.84
NO.85	NO.86	NO.87	NO.88
NO.89	NO.90	NO.91	NO.92
NO.93	NO.94	NO.95	NO.96
NO.97	NO.98	NO.99	NO.100

广东维杰物料自动化系统有限公司  
Guangdong WJZY system company  
操作按钮电话  
4001888888 138231201  
WJ-120231201