

40Gb/s QSFP+ Active Optical Cable

PRODUCT FEATURES

- Full duplex 4 channel 850nm parallel active optical cable
- Up to 11.1Gbps Data rate per channel
- Maximum link length of 300m links on OM3 multimode fiber
- High Reliability 850nm VCSEL technology
- Electrically hot-pluggable
- Case operating temperature range:0°C to 70°C
- Power dissipation < 1.5 W per cable end

APPLICATIONS

- 40G Ethernet
- Infiniband QDR
- Fiber channel
- HPC Interconnections

STANDARD

- Compliant to QSFP+ MSA
- RoHS Compliant.

Product selection

Part Number	Product description
QSFP+-AOC-XXX	XXX=different cable lengths on OM3 Multimode Fiber (MMF) –Note
XXX	cable lengths on OM3 Multimode Fiber (MMF)-max 300m
003	3m
005	5m
007	7m
010	10m
050	50m
100	100m

Note:

More detail product selection and cable lengths, please contact sales。

I Absolute Maximum Ratings

Parameter	Symbol	Min.	Typ.	Max.	Unit	Note
Storage Temperature	Ts	-40	-	85	°C	
Relative Humidity	RH	5	-	95	%	
Power Supply Voltage	VCC	-0.3	-	4	V	
Signal Input Voltage		Vcc-0.3	-	Vcc+0.3	V	

II Recommended Operating Conditions

Parameter	Symbol	Min.	Typ.	Max.	Unit	Note
Case Operating Temperature	Tcase	0	-	70	°C	Without air flow
Power Supply Voltage	VCC	3.14	3.3	3.46	V	
Power Supply Current	ICC	-		450	mA	per cable end
Data Rate	BR		10.3125		Gbps	Each channel

III General Product Characteristics

Parameter	Value	Unit	Notes
Module Form Factor	QSFP+		
Number of Lanes	4 Tx /Rx		
Maximum Aggregate Data Rate	42.0	Gb/s	
Maximum Data Rate per Lane	10.5	Gb/s	
Standard Cable Lengths	3, 5, 7, 10, 50, 100	meters	Other lengths, please contact sales
Protocols Supported	Typical applications include Infiniband, Fiber Channel, 40G Ethernet		
Electrical Interface and Pin-out	38-pin edge connector		Pin-out as defined by the QSFP+ MSA
Standard Optical Cable Type	Multimode ribbon fiber cable assembly, riser-rated		
Maximum Power Consumption per End	1.5	W	
Management Interface	Serial, I2C-based, 400 kHz maximum frequency		As defined by the QSFP+ MSA

IV. Electrical Characteristics

Parameter	Symbol	Min	Typ	Max	Unit	NOTE
Supply Voltage	Vcc1, VccTx, VccRx	3.14	3.3	3.46	V	
Supply Current	Icc			450	mA	
Transmitter						
Differential data input swing	V _{in,pp}	180		1000	mV	1
Single ended input voltage tolerance	V _{inT}	-0.3		4.0	V	
Receiver						
Differential data output swing	V _{out,pp}	300		850	mV	2
Single-ended output voltage		-0.3		4.0	V	

Notes:

1. AC coupled internally. See Figure 1 for input eye mask requirements. Self-biasing 100Ω differential input.
2. AC coupled with 100Ω differential output impedance. See Figure 2 for output eye mask.

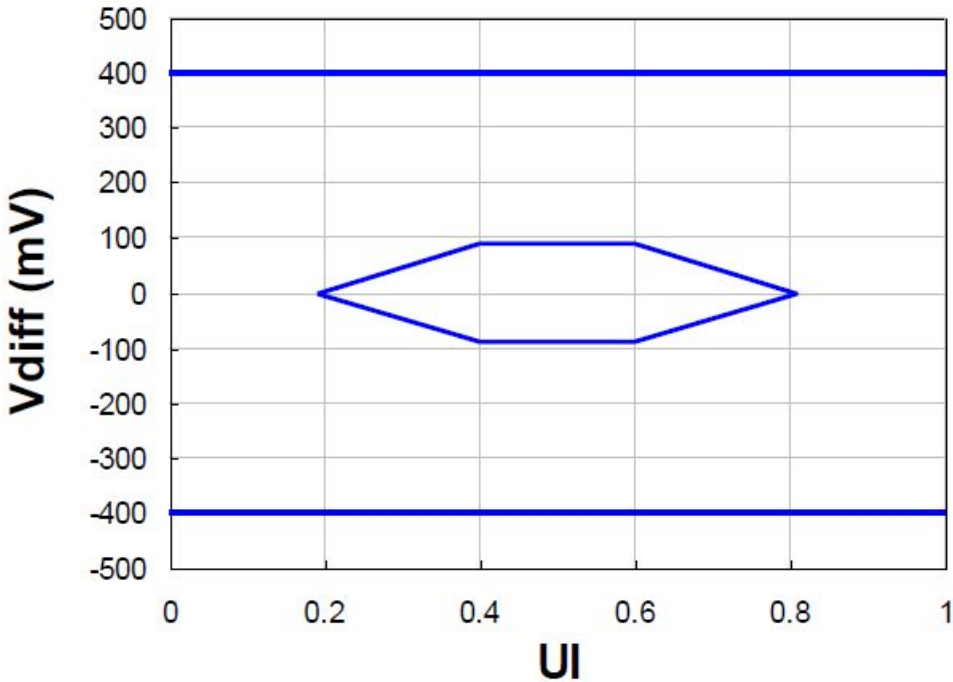

Figure 1 – Transmitter Input Differential Signal Mask

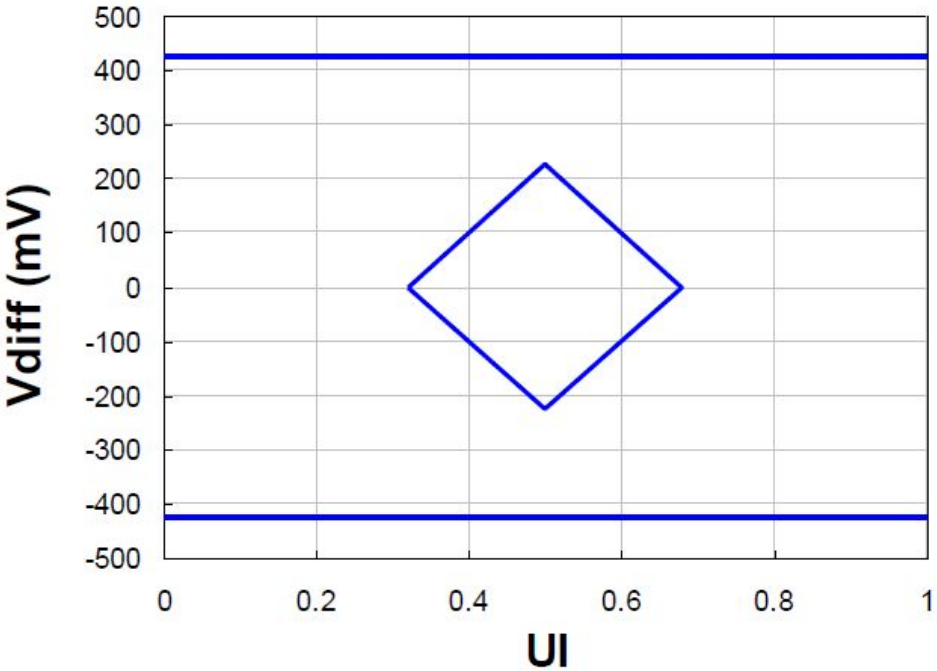

Figure 2 – Receiver Output Differential Signal Mask

V. High-speed Electrical Characteristics per Lane

Parameter-Inputs	Symbol	Min	Typ	Max	Unit	NOTE
Reference Differential Input Impedance	Zd		100		Ω	
Termination Mismatch	ΔZM			5	%	1
Input AC Common Mode Voltage				25	mV (RMS)	
Differential Input Return Loss	SDD11				dB	2 , 0.01-4.1 GHz
					dB	3, 4.1 – 11.1 GHz
Differential to Common Mode Loss	SCD11			-10	dB	0.01-11.1 GHz
Jitter Tolerance (Total)	TJ			0.40	UI	
Jitter Tolerance (Deterministic)	DJ			0.15	UI	

Notes:

1. See SFF-8431 section D.15 Termination Mismatch for definition & test recommendations
2. Reflection coefficient given by equation $SDD11(dB) < -12 + 2 * \sqrt{f}$, with f in GHz. See Figure 3.
3. Reflection coefficient given by equation $SDD11(dB) < -6.3 + 13 \log_{10}(f/5.5)$, with f in GHz. See Figure 3

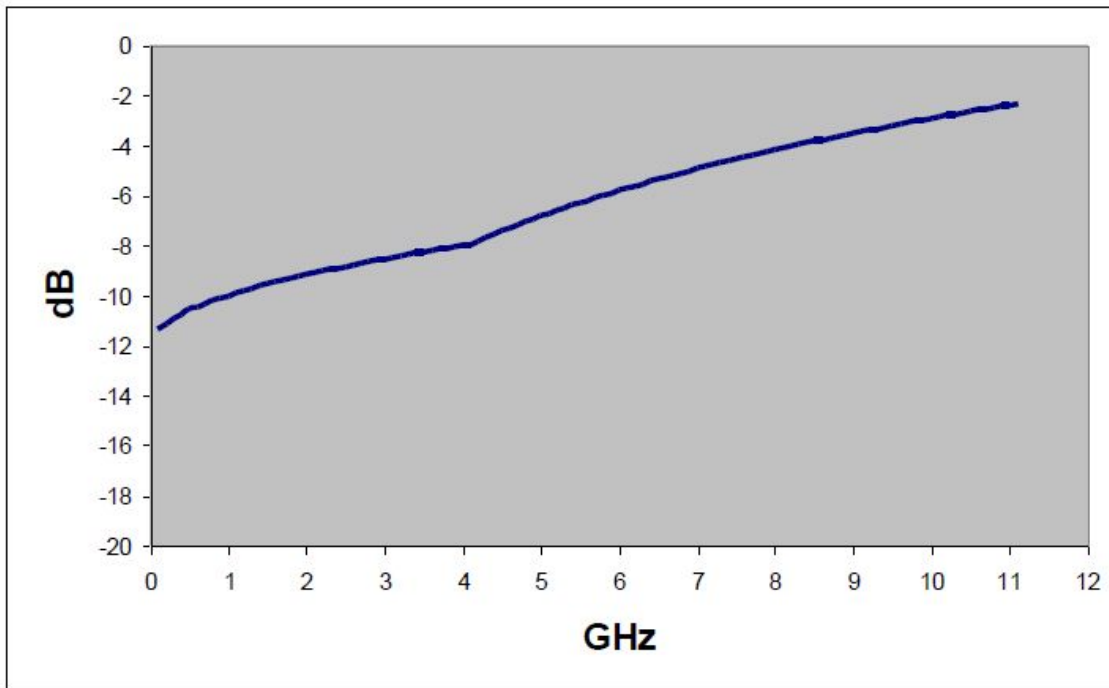

Figure 3 – Maximum Transmitter Input and Receiver Output Differential Return Loss

Parameter-Outputs	Symbol	Min	Typ	Max	Unit	NOTE
Reference Differential Output Impedance	Zd		100		Ω	
Termination Mismatch	ΔZM			5	%	
Output AC Common Mode Voltage				15	mV (RMS)	
Differential Output Return Loss	SDD22				dB	4 , 0.01-4.1 GHz
					dB	5 , 4.1 – 11.1 GHz

Common Mode Output Return Loss	SCC22				dB	6, 0.01-2.5 GHz
				-3	dB	2.5-11.1 GHz
Output Rise and Fall time (20% to 80%)	tRH, tFH	24			ps	
Deterministic Jitter	DJOUT			0.38	UI	7
Total Jitter	TJOUT			0.64	UI	7

Notes:

4. Reflection coefficient given by equation $SDD22(dB) < -12 + 2 * \sqrt{f}$, with f in GHz. See Figure 3.
5. Reflection coefficient given by equation $SDD22(dB) < -6.3 + 13 \log_{10}(f/5.5)$, with f in GHz. See Figure 3.
6. Reflection coefficient given by equation $SCC22(dB) < -7 + 1.6 * f$, with f in GHz.
7. When transmitter input jitter specs are met.

VI. Pin Assignment

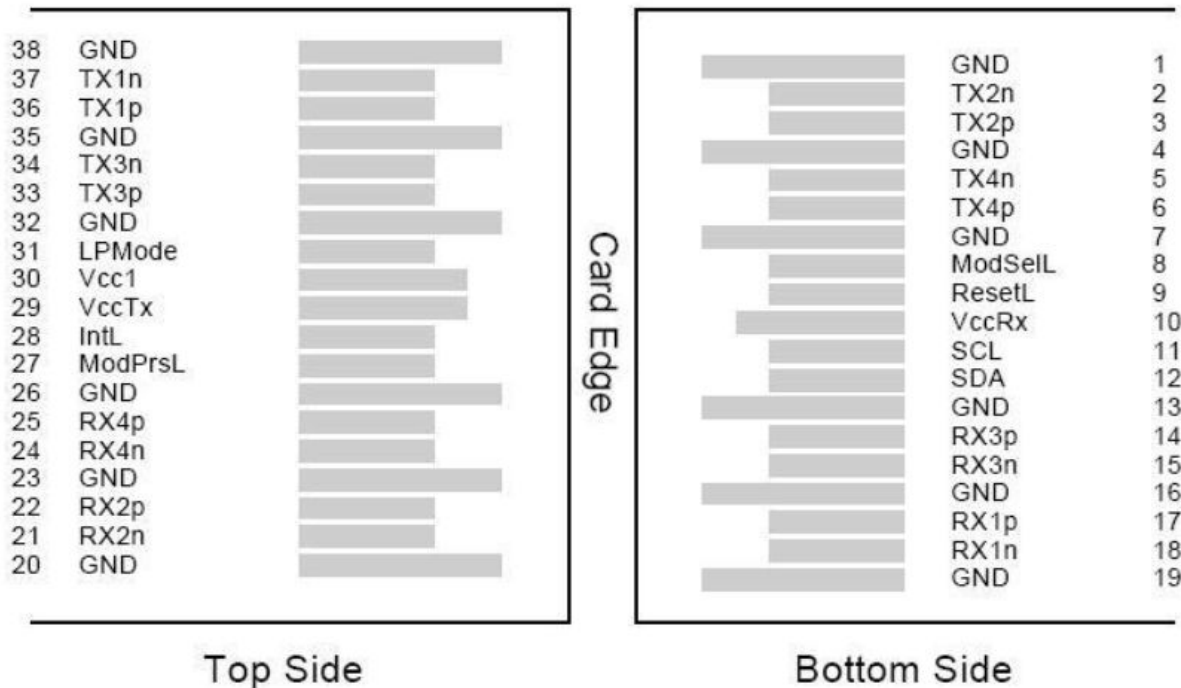

Figure 4---Pin out of Connector Block on Host Board

Pin	Symbol	Name/Description	NOTE
1	GND	Transmitter Ground (Common with Receiver Ground)	1
2	Tx2n	Transmitter Inverted Data Input	
3	Tx2p	Transmitter Non-Inverted Data output	
4	GND	Transmitter Ground (Common with Receiver Ground)	1
5	Tx4n	Transmitter Inverted Data Input	
6	Tx4p	Transmitter Non-Inverted Data output	
7	GND	Transmitter Ground (Common with Receiver Ground)	1
8	ModSelL	Module Select	
9	ResetL	Module Reset	
10	VccRx	3.3V Power Supply Receiver	2
11	SCL	2-Wire serial Interface Clock	
12	SDA	2-Wire serial Interface Data	
13	GND	Transmitter Ground (Common with Receiver Ground)	
14	Rx3p	Receiver Non-Inverted Data Output	

15	Rx3n	Receiver Inverted Data Output	
16	GND	Transmitter Ground (Common with Receiver Ground)	1
17	Rx1p	Receiver Non-Inverted Data Output	
18	Rx1n	Receiver Inverted Data Output	
19	GND	Transmitter Ground (Common with Receiver Ground)	1
20	GND	Transmitter Ground (Common with Receiver Ground)	1
21	Rx2n	Receiver Inverted Data Output	
22	Rx2p	Receiver Non-Inverted Data Output	
23	GND	Transmitter Ground (Common with Receiver Ground)	1
24	Rx4n	Receiver Inverted Data Output	1
25	Rx4p	Receiver Non-Inverted Data Output	
26	GND	Transmitter Ground (Common with Receiver Ground)	1
27	ModPrsl	Module Present	
28	IntL	Interrupt	
29	VccTx	3.3V power supply transmitter	2
30	Vcc1	3.3V power supply	2
31	LPMODE	Low Power Mode, not connect	
32	GND	Transmitter Ground (Common with Receiver Ground)	1
33	Tx3p	Transmitter Non-Inverted Data Input	
34	Tx3n	Transmitter Inverted Data Output	
35	GND	Transmitter Ground (Common with Receiver Ground)	1
36	Tx1p	Transmitter Non-Inverted Data Input	
37	Tx1n	Transmitter Inverted Data Output	
38	GND	Transmitter Ground (Common with Receiver Ground)	1

Notes:

1. GND is the symbol for signal and supply (power) common for QSFP+ modules. All are common within the QSFP+ module and all module voltages are referenced to this potential unless otherwise noted. Connect these directly to the host board signal common ground plane.
2. VccRx, Vcc1 and VccTx are the receiving and transmission power suppliers and shall be applied concurrently. Recommended host board power supply filtering is shown below. Vcc Rx, Vcc1 and Vcc Tx may be internally connected within the QSFP+ transceiver module in any combination. The connector pins are each rated for a maximum current of 500mA.

VII. Host - Transceiver Interface Block Diagram

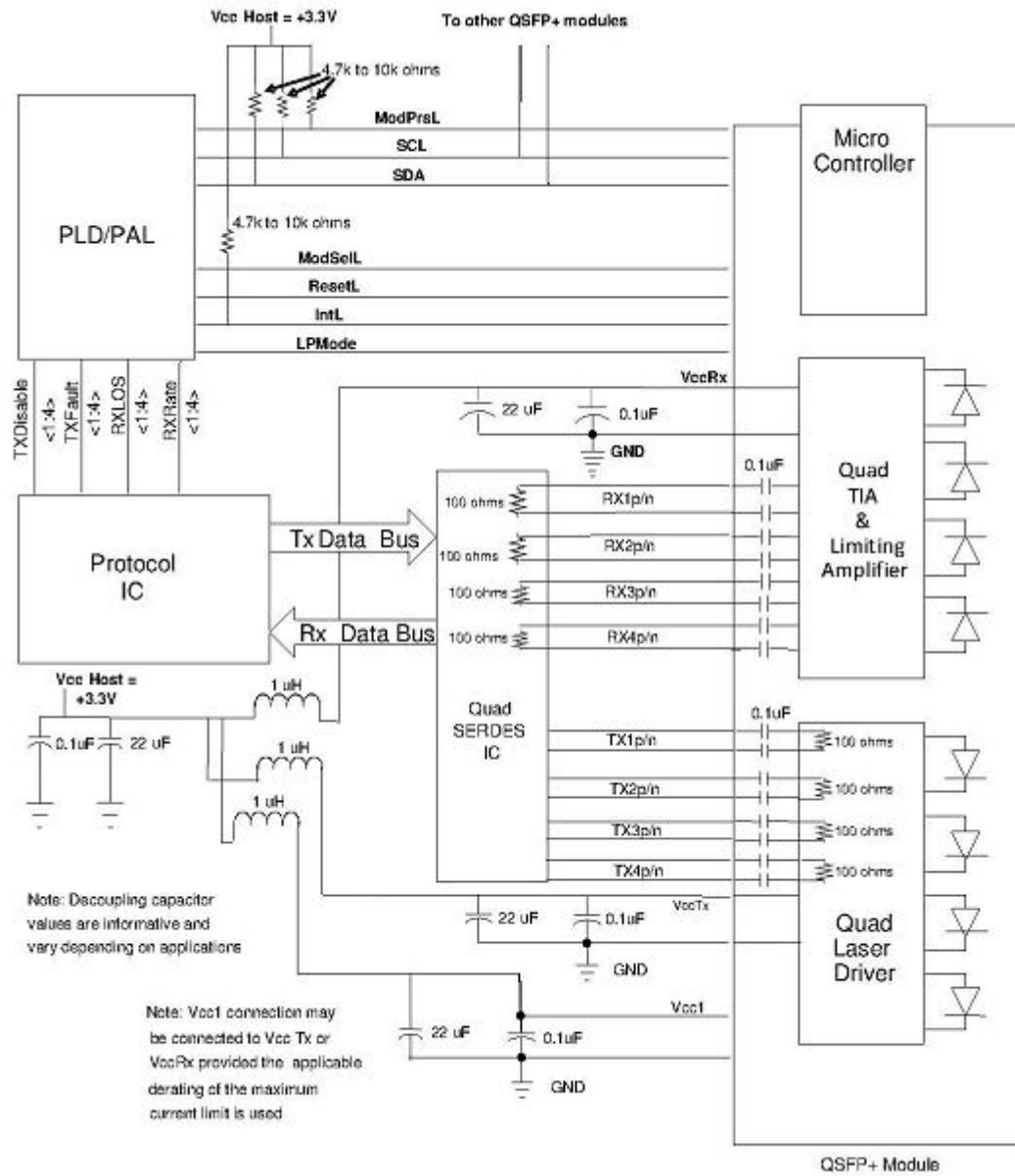

VIII. Outline Dimensions

