

RoHS
compliant

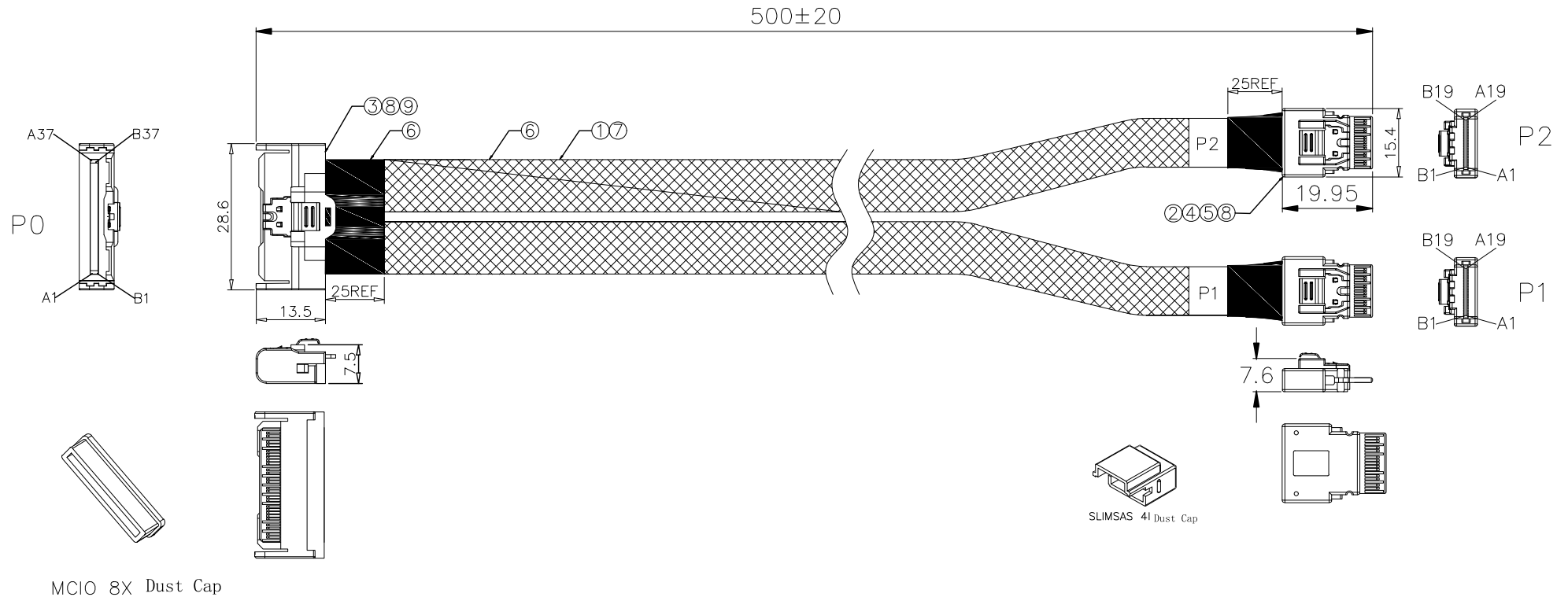

9	HUOSING	AQ-3-MS64011	PA66+30%GF,BALCK	1	PCS
8	LATCH	AQ-3-MS21008	STAINLESS STEEL	3	PCS
7	EXPANDO	AQ-3-MS76001	PET BALCK DD: 10mm	A/R	mm
6	ACETATE TAPE	AQ-3-MS77001	ACETATE TAPE,BLACK	25	mm
5	MOLDING	AQ-3-GL100101	LDPE,NATURAL	A/R	9
4	MOLDING	AQ-3-GL100401	PBT+30GF% BLACK	A/R	9
3	PCBA	AQ-3-MS31027	MCIO 8I PCB, PIN:30u Au, 88±8 ohm	1	PCS
2	PCBA	AQ-3-MS31026	SLIMSAS 4I PCB, PIN:30u Au, 88±8 ohm	2	PCS
1	CABEL	AQ-3-MS40208	(30AWG*2C+2D)AL+MYLAR,DD:0.8*1.76MM,85±5 ohm	A/R	mm
NO.	PART NAME	PART NO.	SPEC DESCRIPTION	QT'Y	UNIT

TOLERANCE							
INCHES		M/M					
.X	.015	.30					
.XX	.010	.10					
.XXX	.005	.05					
DRAWN BY	TONY CHAN		SCALE	NONE		REV	A0
CHECK BY	LJF		UNIT	MM			
APPD BY			SHEET	1/2	CUSTOMER:		
CUSTOMER. P/N:			DATE	23/04/06	DWG NO.:AQ03-0219A		
			TITLE: MCIO 8i TO 2*SLIMSAS 4i CABLE				
			P/N: AMSE90010001				

OIKWAN® 东莞市嵩群实业有限公司
DONGGUAN AIQUINDUSTRIAL CO., LTD.

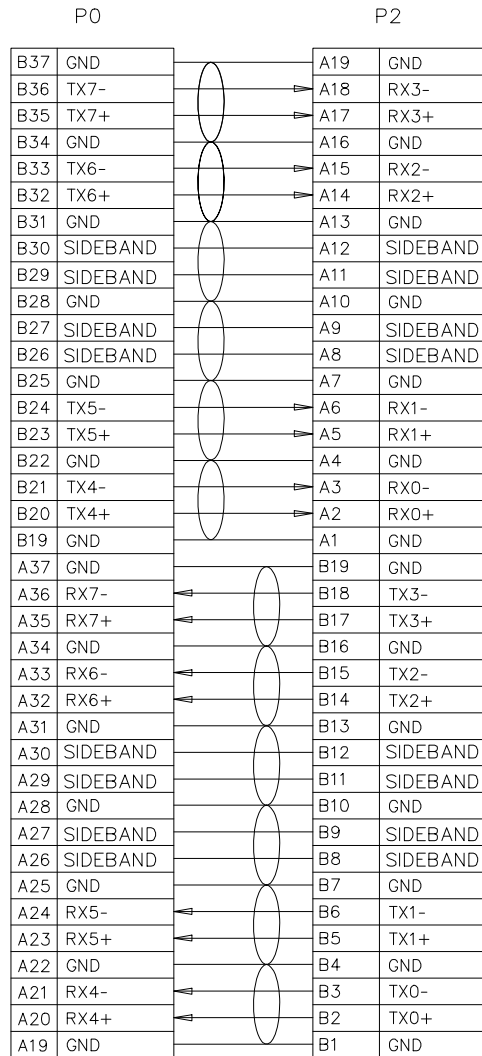
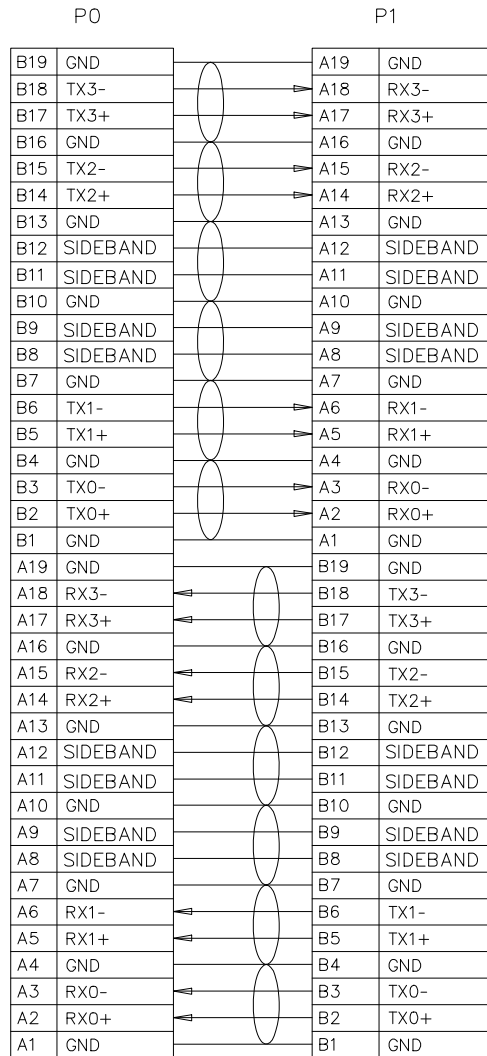

ELECTRICAL CHARACTER:

- a. 100% OPEN&SHORT TESTING;
- b. WITHSTANDING VOLTAGE:DC 300V 0.01Sec;
- c. INSULATION RESISTANCE:10M Ohm(Min);
- d. CONDUCTIVE RESISTANCE:2 Ohm(Max).

TOLERANCE INCHES			M/M			OIKWAN® DONGGUAN A■QUN ■INDUSTRI■AL CO., LTD.		
.X	.015	.30	SCALE	NONE		REV	AO	
.XX	.010	.10	UNIT	MM				
.XXX	.005	.05	DRAWN BY	TONY CHAN		SHEET	2/2	CUSTOMER:
			CHECK BY	LJF		DATE	23/04/06	DWG NO.:AQ03-0219A
			APPD BY			TITLE: MCIO 8i TO 2*SLIMSAS 4i CABLE		
			CUSIOMER. P/N:			P/N: AMSE90010001		