

EMC TEST REPORT



For Electromagnetic Interference of

Report Reference No..... :	E01A22060003E00101
Engineer (name + signature)..... :	Duke Liu
Reviewed by (name + signature)..... :	Tiger Xu
Approved by (name + signature)..... :	Tomas Yang
Date of Receipt of EUT..... :	Jun. 02, 2022
Date of Test..... :	Jun. 02, 2022 to Jun. 10, 2022
Date of Issue..... :	Jun. 21, 2022
Testing Laboratory..... :	Dongguan Anci Electronic Technology Co., Ltd.
Address..... :	1-2 Floor, Building A, No.11, Headquarters 2 Road, Songshan Lake Hi-tech Industrial Development Zone, Dongguan City, Guangdong, China
Laboratory location..... :	EMC Laboratory
Applicant's name..... :	ShengHui Electronic Technology(Guangdong)Co., Ltd.
Address..... :	Room 301, No. 61, 3rd Street, Changtang 3rd Industrial Zone, Dalang Town, Dongguan, Guangdong, China523775
Manufacturer..... :	Same as Applicant
Address..... :	Same as Applicant
Factory's name..... :	Same as Applicant
Address..... :	Same as Applicant





Test specification:

EUT description.....:	Deodorant Cat Litter Box
Trade Mark.....:	N/A
Model/Type reference..... :	SH2116
Test Sample.....:	SH2116
Ratings..... :	Deodorant Cat Litter Box input:5.0V $\overline{=}$ 1.0A Adapter input:100-240V~50/60H 0.15A Adapter output:5.0V $\overline{=}$ 1.0A 5.0W
Tested Power.....:	Input: 230Vac,50Hz
Standards.....:	EN IEC 55014-1:2021 EN IEC 55014-2:2021 EN IEC 61000-3-2:2019+A1:2021 EN 61000-3-3:2013+A2:2021

The device described above was tested by Dong Guan Anci Electronic Technology Co., Ltd. to determine the maximum emission levels emanated from the device and severity levels of the device endure and its performance criterion. The measurement results are contained in this test report and Dong Guan Anci Electronic Technology Co., Ltd. assumes full responsibility for the accuracy and completeness of these measurements. This report shows the EUT is technically compliance with the above official standards.

This report applies to the above sample only and shall not be reproduced in part without written approval of Dong Guan Anci Electronic Technology Co., Ltd.

Table of Contents	Page
1. GENERAL INFORMATION	6
1.1 PRODUCT INFORMATION	6
1.2 Details about the Test Laboratory	7
2. SUMMARY OF TEST RESULTS	9
2.1 MEASUREMENT UNCERTAINTY	11
2.2 DESCRIPTION OF TEST MODES	11
2.3 BLOCK DIGRAM SHOWING THE CONFIGURATION OF SYSTEM TESTED	12
3. EMISSION TEST	13
3.1 CONDUCTED EMISSION MEASUREMENT	13
3.1.1 LIMITS OF CONDUCTED EMISSION(MAINS PORT)	13
3.1.2 MEASUREMENT INSTRUMENTS LIST	13
3.1.3 TEST PROCEDURE	14
3.1.4 DEVIATION FROM TEST STANDARD	14
3.1.5 TEST SETUP	15
3.1.6EUT OPERATING CONDITIONS	15
3.1.7 TEST RESULTS	16
3.2 DISTURBANCE POWER MEASUREMENT	21
3.2.2 MEASUREMENT INSTRUMENTS LIST	21
3.2.3 TEST PROCEDURE	21
3.2.4 DEVIATION FROM TEST STANDARD	21
3.2.5 TEST SETUP	22
3.2.6 EUT OPERATING CONDITIONS	22
3.3 HARMONICS CURRENT MEASUREMENT	28
3.3.1 LIMITS OF HARMONICS CURRENT MEASUREMENT	28
3.3.2 MEASUREMENT INSTRUMENTS LIST	29
3.3.3 TEST PROCEDURE	29
3.3.4 DEVIATION FROM TEST STANDARD	29
3.3.5 TEST SETUP	29
3.3.6 EUT OPERATING CONDITIONS	29
3.4 VOLTAGE FLUCTUATION AND FLICKS MEASUREMENT	30
3.4.1 LIMITS OF VOLTAGE FLUCTUATION AND FLICKSMEASUREMENT	30
3.4.2 MEASUREMENT INSTRUMENTS LIST	30
3.4.3 TEST PROCEDURE	30
3.4.4 DEVIATION FROM TEST STANDARD	30
3.4.5 TEST SETUP	31



Table of Contents	Page
3.4.6 EUT OPERATING CONDITIONS	31
3.4.7 TEST RESULTS	32
4. IMMUNITY TEST	33
4.1 STANDARD COMPLIANCE/SERVIRITY LEVEL/CRITERIA	33
4.2 GENERAL PERFORMANCE CRITERIA	35
4.3 GENERAL PERFORMANCE CRITERIA TEST SETUP	35
4.4 ESD TESTING	36
4.4.1 TEST SPECIFICATION	36
4.4.2 MEASUREMENT INSTRUMENTS	36
4.4.3 TEST PROCEDURE	36
4.4.4 DEVIATION FROM TEST STANDARD	37
4.4.5 TEST SETUP	37
4.4.6 TEST RESULTS	38
4.5 RS TESTING	39
4.5.1 TEST SPECIFICATION	39
4.5.2 MEASUREMENT INSTRUMENTS	39
4.5.3 TEST PROCEDURE	39
4.5.4 DEVIATION FROM TEST STANDARD	39
4.5.5 TEST SETUP	40
4.6 EFT/BURST TESTING	41
4.6.1 TEST SPECIFICATION	41
4.6.2 MEASUREMENT INSTRUMENTS	41
4.6.3 TEST PROCEDURE	41
4.6.4 DEVIATION FROM TEST STANDARD	41
4.6.5 TEST SETUP	42
4.6.6 TEST RESULTS	43
4.7 SURGE TESTING	44
4.7.1 TEST SPECIFICATION	44
4.7.2 MEASUREMENT INSTRUMENTS	44
4.7.3 TEST PROCEDURE	44
4.7.4 DEVIATION FROM TEST STANDARD	45
4.7.5 TEST SETUP	45
4.7.6 TEST RESULTS	46
4.8 INJECTION CURRENT TESTING	47
4.8.1 TEST SPECIFICATION	47
4.8.2 MEASUREMENT INSTRUMENTS	47
4.8.3 TEST PROCEDURE	47
4.8.4 DEVIATION FROM TEST STANDARD	47



Table of Contents	Page
4.8.5 TEST SETUP	48
4.8.6 TEST RESULTS	49
4.9 VOLTAGE INTERRUPTION/DIPS TESTING	50
4.9.1 TEST SPECIFICATION	50
4.9.2 MEASUREMENT INSTRUMENTS	50
4.9.3 TEST PROCEDURE	50
4.9.4 DEVIATION FROM TEST STANDARD	50
4.9.5 TEST SETUP	51
4.9.6 TEST RESULTS	51
5. ATTACHMENT	52
5.1 EUT TEST PHOTO	52
5.2 EUT PHOTO	56



1. GENERAL INFORMATION

1.1 PRODUCT INFORMATION

The product is Deodorant Cat Litter Box for the used only for household and indoor.

The model tested in the report is SH2116.

The EUT passed the test.



1.2 Details about the Test Laboratory

Test Site 1:

Company name:Dongguan Anci Electronic Technology Co., Ltd.

Address:1-2 Floor, Building A, No.11, Headquarters 2 Road, Songshan Lake
Hi-tech Industrial Development Zone, Dongguan City,
Guangdong Pr., China.

Telephone: +86-769- 8507 5888

Fax: +86-769- 8507 5898

Test Site 2:

Company name:Guangdong Dongguan Quality Supervision Testing Center

Address:No.2 South Industry Road, Dongguan Songshan Lake
Sci.&Tech. Industrial Park,Guangdong Province, China

Telephone: +86 769 2307 1111

Fax: +86 769 2307 7221

Standard	Test Item	Test Site
EN IEC 55014-1:2021	Conducted Emission	1
	Disturbance Power Measurement	1
	Radiated Emission	N/A
EN IEC 61000-3-2:2019+A1:2021	Harmonic Current Emission	N/A
EN 61000-3-3:2013+A2:2021	Voltage Fluctuations & Flicker	1
EN 61000-4-2:2009	Electrostatic Discharge	1
EN 61000-4-3:2006+A1:2008+A2:2010	RF electromagnetic field	N/A
EN 61000-4-4:2012	Fast transients	1
EN 61000-4-5:2014+A1:2017	Surges	1
EN 61000-4-6:2014	Injected Current	2
EN IEC 61000-4-11:2020	Volt. Interruptions Volt. Dips	1

2. SUMMARY OF TEST RESULTS

Test procedures according to the technical standards:

Emission				
Standard	Test Item	Judgment	Remark	
EN IEC 55014-1:2021	Conducted Emission	PASS		
	Disturbance Power Measurement	PASS		
	Radiated Emission	N/A	NOTE (4)	
EN IEC 61000-3-2:2019+A1:2021	Harmonic Current Emission	N/A		
EN61000-3-3:2013+A2:2021	Voltage Fluctuations & Flicker	PASS		
Immunity (EN IEC 55014-2:2021)				
Section	Test Item	Performance Criteria	Judgment	Remark
EN 61000-4-2:2009	Electrostatic Discharge	B	PASS	
EN 61000-4-3:2006+A1:2008+A2:2010	RF electromagnetic field	A	N/A	
EN 61000-4-4:2012	Fast transients	B	PASS	
EN 61000-4-5:2014+A1:2017	Surges	B	PASS	
EN 61000-4-6:2014	Injected Current	A	PASS	
EN IEC 61000-4-11:2020	Volt. Interruptions Volt. Dips	C NOTE (3)	PASS	

NOTE:

- (1) "N/A" denotes test is not applicable in this Test Report
- (2) The power consumption of EUT is less than 75W and no Limits apply.
- (3) Voltage dip: 30% reduction – Performance Criteria **C**
 Voltage dip: 60% reduction – Performance Criteria **C**
 Voltage Interruption: 100% reduction – Performance Criteria **C**

(4) Appliances are deemed to comply in the frequency range from 300 MHz to 1 000 MHz if both of the following conditions (1) and 2)) are fulfilled:

- 1) all emission readings from the equipment under test shall be lower than the applicable limits reduced by the margin;
- 2) the maximum clock frequency shall be less than 30 MHz.

If either of condition 1) or 2) is not fulfilled, radiated measurements in the frequency range from 300 MHz to 1 000 MHz shall be conducted and the limits of Table 3 for that range applied. In any case the limits of Table 2a in the frequency range 30 MHz to 300 MHz shall be met.

(5) Denotes test is not applicable in this test report and no Limits apply.

2.1 MEASUREMENT UNCERTAINTY

The reported uncertainty of measurement $y \pm U$, where expended uncertainty U is based on a standard uncertainty multiplied by a coverage factor of $k=2$, providing a level of confidence of approximately 95 %.

A. Conducted Measurement :

Test Site	Method	Measurement Frequency Range	U (dB)	NOTE
C01	ANSI	150 KHz ~ 30MHz	3.19	

B. Disturbance Power Measurement :

Test Site	Method	Measurement Frequency Range	U (dB)	NOTE
C01	ANSI	30 MHz ~ 300MHz	3.26	

2.2 DESCRIPTION OF TEST MODES

To investigate the maximum EMI characteristics generates from EUT, the test system was pre-scanning tested base on the consideration of following EUT operation mode or test configuration mode which possible have effect on EMI level. Each of these EUT operation mode(s) or test configuration mode(s) mentioned above was evaluated respectively.

For Emission Test	
Test Mode	Description
Mode 1	Max power
Mode 2	Min power

For Immunity Test	
Test Mode	Description
Mode 1	Max power
Mode 2	Min power

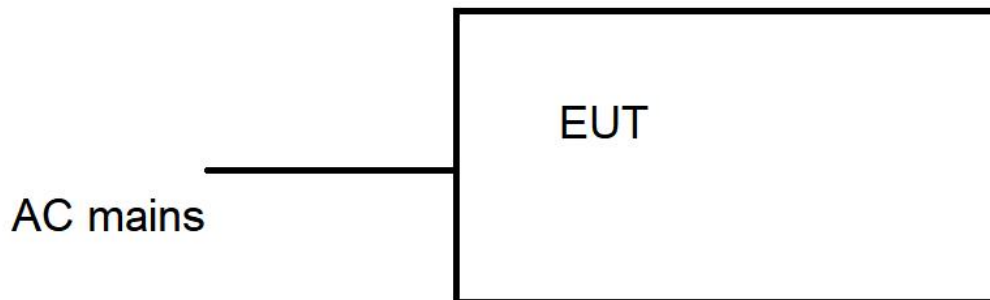
2.3 BLOCK DIGRAM SHOWING THE CONFIGURATION OF SYSTEM TESTED

The EUT has been tested as an independent unit together with other necessary accessories or support units. The following support units or accessories were used to form a representative test configuration during the tests.

3. EMISSION TEST

3.1 CONDUCTED EMISSION MEASUREMENT

3.1.1 LIMITS OF CONDUCTED EMISSION(MAINS PORT) (Frequency Range 150KHz-30MHz)

FREQUENCY (MHz)	Limit (dBuV)	
	Quasi-peak	Average
0.15 -0.5	66 - 56 *	59 - 46 *
0.50 -5.0	56.00	46.00
5.0 -30.0	60.00	50.00

Note:

- (1) The tighter limit applies at the band edges.
- (2) The limit of " * " marked band means the limitation decreases linearly with the logarithm of the frequency in the range.
- (3) The test result calculated as following:

Measurement Value = Reading Level + Correct Factor

Correct Factor = Insertion Loss + Cable Loss + Attenuator Factor(if use)

Margin Level = Measurement Value - Limit Value

The following table is the setting of the receiver

Receiver Parameters	Setting
Attenuation	10 dB
Start Frequency	0.15 MHz
Stop Frequency	30 MHz
IF Bandwidth	9 kHz

3.1.2 MEASUREMENT INSTRUMENTS LIST

Item	Instr.Code	Kind of Equipment	Manufacturer	Type No.	Serial No.	Calibrated until
1	AN-E010	L.I.S.N	SCHWARZBECK	NSLK 8127	8127-669	2023-05-12
2	AN-E028	TRANSIENT LIMITER	CYBERTEK	EM5010A	E1950100113	2023-05-12
3	AN-E022	RF Cable	N/A	ZT06S-BNCJ-NJ-7.5M	19044020	2023-05-12
4	AN-E020	EMI Test Receiver	ROHDE&SCHWARZ	ESCI	101358	2023-05-12
5	AN-E058	1# Shielded Room	chengyu	8m*4m*3.3m	N/A	2024-11-12
6	AN-E046	Test Software	Farad	EZ-EMC Ver:ANCI-8A1	N/A	N/A

Remark: " N/A " denotes No Model No. , Serial No. or No Calibration specified.

3.1.3 TEST PROCEDURE

- a. The EUT was placed 0.4 meters from the horizontal ground plane with EUT being connected to the power mains through a line impedance stabilization network (LISN). All other support equipments powered from additional LISN(s). The LISN provide 50 Ohm/ 50uH of coupling impedance for the measuring instrument.
- b. Interconnecting cables that hang closer than 40 cm to the ground plane shall be folded back and forth in the center forming a bundle 30 to 40 cm long.
- c. I/O cables that are not connected to a peripheral shall be bundled in the center. The end of the cable may be terminated, if required, using the correct terminating impedance. The overall length shall not exceed 1 m.
- d. LISN at least 80 cm from nearest part of EUT chassis.
- e. For the actual test configuration, please refer to the related Item –EUT Test Photos.

3.1.4 DEVIATION FROM TEST STANDARD

No deviation

3.1.5 TEST SETUP

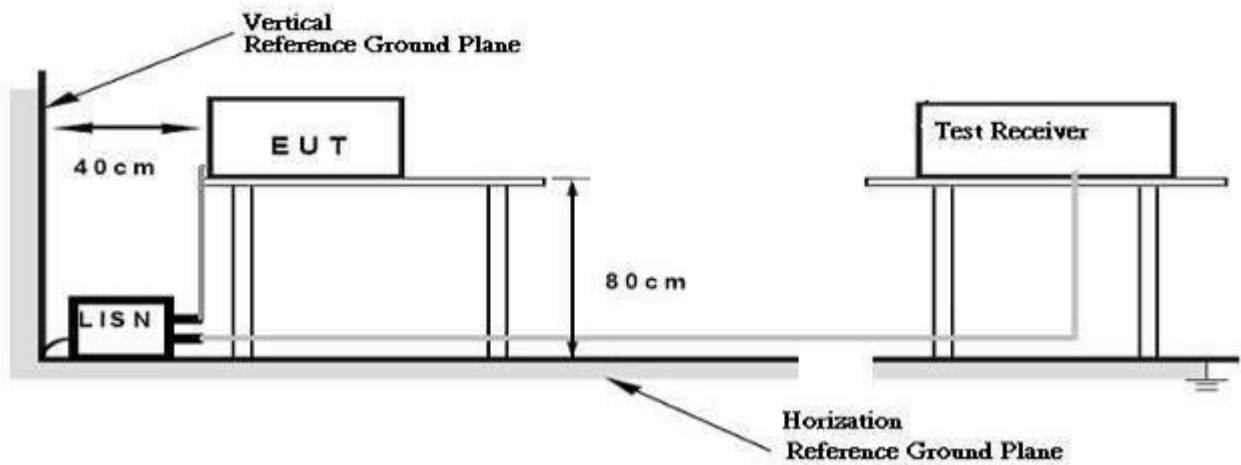

3.1.6 EUT OPERATING CONDITIONS

The EUT exercise program used during radiated and/or conducted emission measurement was designed to exercise the various system components in a manner similar to a typical use.

**3.1.7 TEST RESULTS**

EUT:	Deodorant Cat Litter Box	Model No. :	SH2116
Temperature:	23.5℃	Relative Humidity:	52.6%
Pressure:	1008 hPa	Test Power :	AC 230V/50Hz
Test Mode :	Max power,Min power		

Remark:

- (1) Reading in which marked as QP means measurements by using Quasi-Peak Detector ,and AV means measurements by using Average Detector.
- (2) All readings are QP Mode value unless otherwise stated AVG in column of 『Note』 . If the QP Mode Measured value compliance with the QP Limits and lower than AVG Limits,the EUT shall be deemed to meet both QP & AVG Limits and then only QP Mode was measured, but AVG Mode didn't perform. In this case, a “ * ” marked in AVG Mode column of Interference Voltage Measured.
- (3) Measuring frequency range from 150KHz to 30MHz.



Site:	843.3	Phase:L1	Temperature(C):23.5(C)
Limit:	EN IEC 55014-1QP		Humidity(%):52.6%
EUT:	Deodorant Cat Litter Box	Test Time:	2022-06-02
M/N.:	SH2116	Power Rating:	AC 230V/50Hz
Mode:	Max power	Test Engineer:	Luffy
Note:			

No.	Frequency (MHz)	Reading Level(dBuV)	Factor (dB)	Measurement(dBuV)	Limit (dBuV)	Over (dB)	Detector	Comment
1	0.3899	37.61	9.89	47.50	58.07	-10.57	QP	
2	0.3899	23.90	9.89	33.79	48.69	-14.90	AVG	
3	0.4100	39.53	9.87	49.40	57.65	-8.25	QP	
4	0.4100	25.81	9.87	35.68	48.14	-12.46	AVG	
5	0.4260	39.94	9.86	49.80	57.33	-7.53	QP	
6	0.4260	28.01	9.86	37.87	47.73	-9.86	AVG	
7	0.4500	40.45	9.85	50.30	56.88	-6.58	QP	
8	0.4500	28.32	9.85	38.17	47.14	-8.97	AVG	
9	0.4740	37.21	9.85	47.06	56.44	-9.38	QP	
10	0.4740	25.22	9.85	35.07	46.58	-11.51	AVG	
11	0.7500	36.66	9.64	46.30	56.00	-9.70	QP	
12	0.7500	23.82	9.64	33.46	46.00	-12.54	AVG	



Site:	843.3	Phase:	N	Temperature(C):	23.5(C)
Limit:	EN IEC 55014-1QP			Humidity(%):	52.6%
EUT:	Deodorant Cat Litter Box	Test Time:	2022-06-02		
M/N.:	SH2116	Power Rating:	AC 230V/50Hz		
Mode:	Max power	Test Engineer:	Luffy		
Note:					

No.	Frequency (MHz)	Reading Level(dBuV)	Factor (dB)	Measurement(dBuV)	Limit (dBuV)	Over (dB)	Detector	Comment
1	0.4060	37.42	9.88	47.30	57.73	-10.43	QP	
2	0.4060	19.03	9.88	28.91	48.25	-19.34	AVG	
3	0.4300	40.43	9.87	50.30	57.25	-6.95	QP	
4	0.4300	23.37	9.87	33.24	47.63	-14.39	AVG	
5	0.4540	39.33	9.87	49.20	56.80	-7.60	QP	
6	0.4540	22.40	9.87	32.27	47.04	-14.77	AVG	
7	0.4700	36.45	9.85	46.30	56.51	-10.21	QP	
8	0.4700	18.14	9.85	27.99	46.67	-18.68	AVG	
9	0.7060	34.13	9.67	43.80	56.00	-12.20	QP	
10	0.7060	15.14	9.67	24.81	46.00	-21.19	AVG	
11	0.7539	35.95	9.65	45.60	56.00	-10.40	QP	
12	0.7539	15.94	9.65	25.59	46.00	-20.41	AVG	

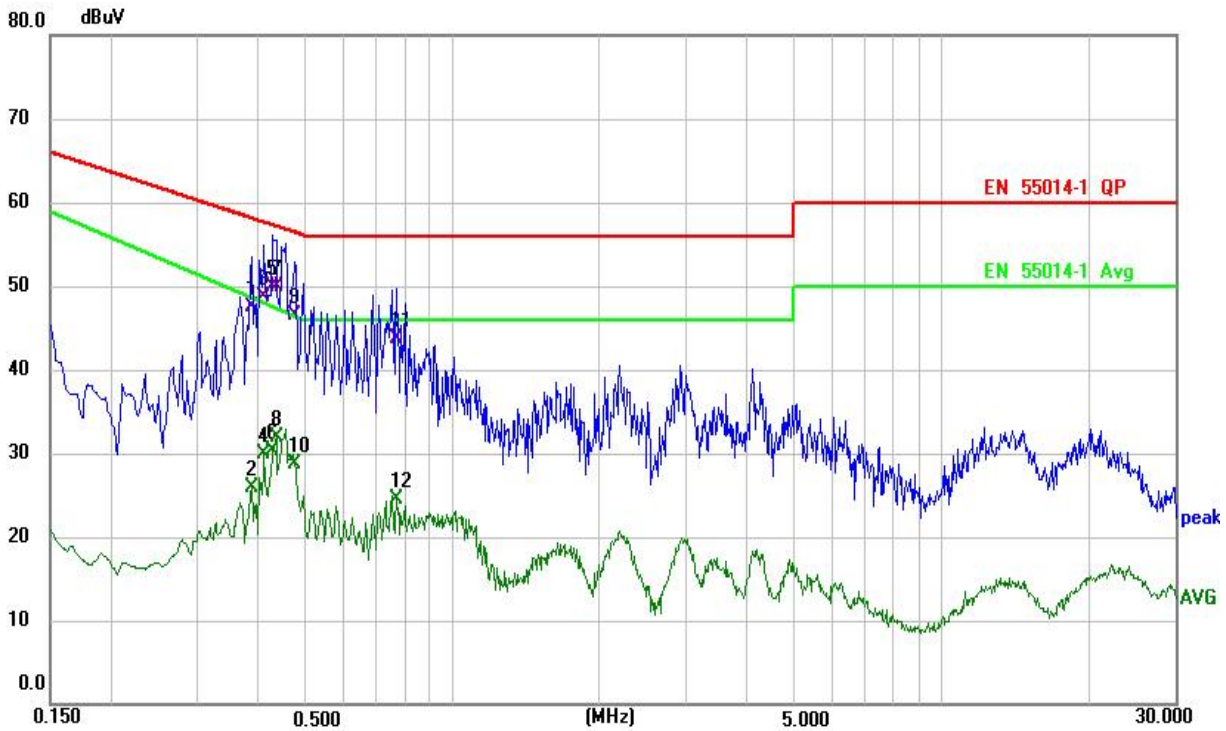

Site:	843.3	Phase:	N	Temperature(C):	23.5(C)
Limit:	EN IEC 55014-1QP			Humidity(%):	52.6%
EUT:	Deodorant Cat Litter Box	Test Time:	2022-06-02		
M/N.:	SH2116	Power Rating:	AC 230V/50Hz		
Mode:	Min power	Test Engineer:	Luffy		
Note:					

No.	Frequency (MHz)	Reading Level(dBuV)	Factor (dB)	Measurement(dBuV)	Limit (dBuV)	Over (dB)	Detector	Comment
1	0.3860	37.59	9.90	47.49	58.15	-10.66	QP	
2	0.3860	16.07	9.90	25.97	48.79	-22.82	AVG	
3	0.4100	38.92	9.88	48.80	57.65	-8.85	QP	
4	0.4100	20.00	9.88	29.88	48.14	-18.26	AVG	
5	0.4260	40.13	9.87	50.00	57.33	-7.33	QP	
6	0.4260	20.43	9.87	30.30	47.73	-17.43	AVG	
7	0.4340	40.03	9.87	49.90	57.18	-7.28	QP	
8	0.4340	21.96	9.87	31.83	47.53	-15.70	AVG	
9	0.4740	36.71	9.85	46.56	56.44	-9.88	QP	
10	0.4740	18.93	9.85	28.78	46.58	-17.80	AVG	
11	0.7700	34.15	9.63	43.78	56.00	-12.22	QP	
12	0.7700	14.97	9.63	24.60	46.00	-21.40	AVG	

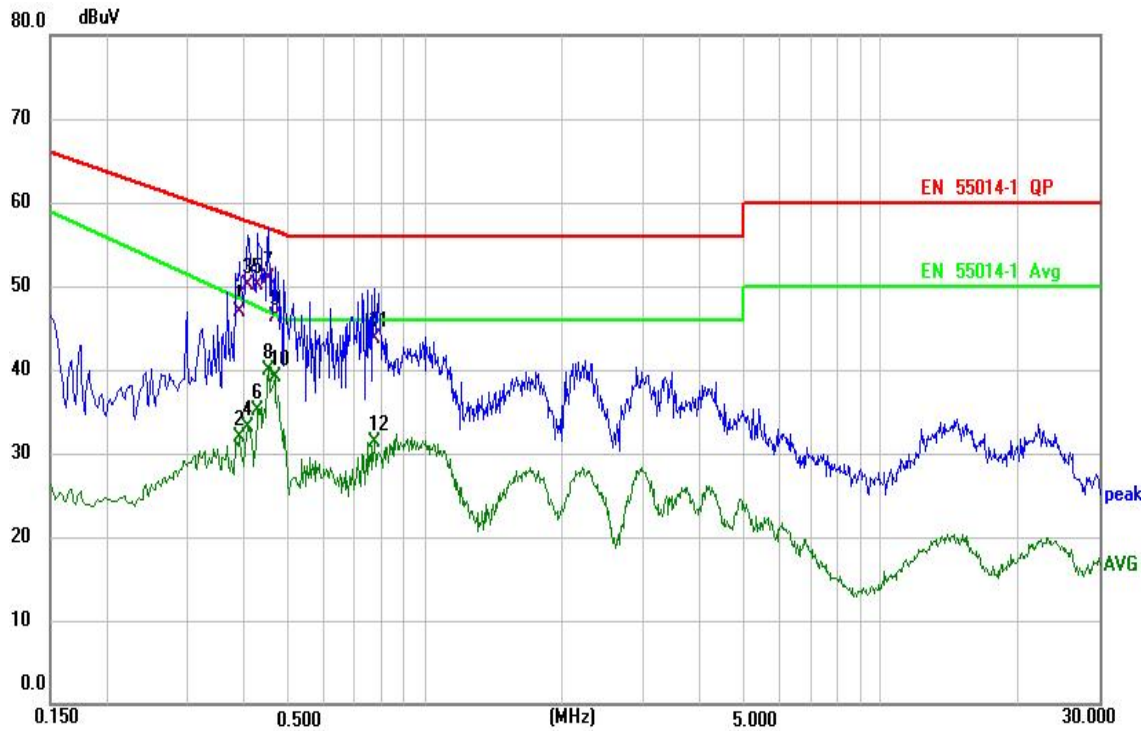

Site:	843.3	Phase:L1	Temperature(C):23.5(C)
Limit:	EN IEC 55014-1QP		Humidity(%):52.6%
EUT:	Deodorant Cat Litter Box	Test Time:	2022-06-02
M/N.:	SH2116	Power Rating:	AC 230V/50Hz
Mode:	Min power	Test Engineer:	Luffy
Note:			

No.	Frequency (MHz)	Reading Level(dBuV)	Factor (dB)	Measurement(dBuV)	Limit (dBuV)	Over (dB)	Detector	Comment
1	0.3899	37.01	9.89	46.90	58.07	-11.17	QP	
2	0.3899	21.94	9.89	31.83	48.69	-16.86	AVG	
3	0.4060	40.23	9.87	50.10	57.73	-7.63	QP	
4	0.4060	23.23	9.87	33.10	48.25	-15.15	AVG	
5	0.4260	40.34	9.86	50.20	57.33	-7.13	QP	
6	0.4260	25.19	9.86	35.05	47.73	-12.68	AVG	
7	0.4500	41.03	9.85	50.88	56.88	-6.00	QP	
8	0.4500	29.98	9.85	39.83	47.14	-7.31	AVG	
9	0.4660	36.49	9.85	46.34	56.58	-10.24	QP	
10	0.4660	29.23	9.85	39.08	46.76	-7.68	AVG	
11	0.7740	34.03	9.63	43.66	56.00	-12.34	QP	
12	0.7740	21.74	9.63	31.37	46.00	-14.63	AVG	

3.2 DISTURBANCE POWER MEASUREMENT

3.2.1 LIMITS OF DISTURBANCE POWER MEASUREMENT

FREQUENCY (MHz)	Limit (at 3m)	
	QP (dBpW)	AV(dBpw)
30 – 300	45 – 55	35 – 45

Notes:

- (1) The tighter limit applies at the band edges.

3.2.2 MEASUREMENT INSTRUMENTS LIST

Item	Instr.Code	Kind of Equipment	Manufacturer	Type No.	Serial No.	Calibrated until
1	AN-E012	Absorbing clamp	LUTHI	MDS 21	4202	2023-05-15
2	AN-E011	6 db attenuator	N/A	N/A	N/A	2023-05-12
3	AN-E008	RF Cable	N/A	Z804-NJ-NJ-10M	19044019	2023-05-12
4	AN-E020	EMI Test Receiver	ROHDE&SCHWARZ	ESCI	101358	2023-05-12
5	AN-E058	1# Shielded Room	chengyu	8m*4m*3.3m	N/A	2024-11-11
6	AN-E046	Test Software	Farad	EZ-EMC Ver:ANCI-8A1	N/A	N/A

Remark: " N/A" denotes No Model No. / Serial No. and No Calibration specified.

3.2.3 TEST PROCEDURE

- a. The EUT was placed on a non-metallic table of 0.8 m of height above the floor and at least 0.8m from other metallic objects and from any person. The lead to be measured shall be stretched in a straight horizontal line for a length sufficient to accommodate the absorbing clamp and to permit the necessary adjustment of its position for tuning.
- b. Any other lead than that to be measured shall disconnected..
- c. At each test frequency the absorbing clamp shall be moved along the lead until the maximum value is found between a position adjacent to the equipment under test and a distance of 6 m
- d. For the actual test configuration, please refer to the related Item –EUT Test Photos.

3.2.4 DEVIATIONFROMTESTSTANDARD

No deviation

3.2.5 TEST SETUP

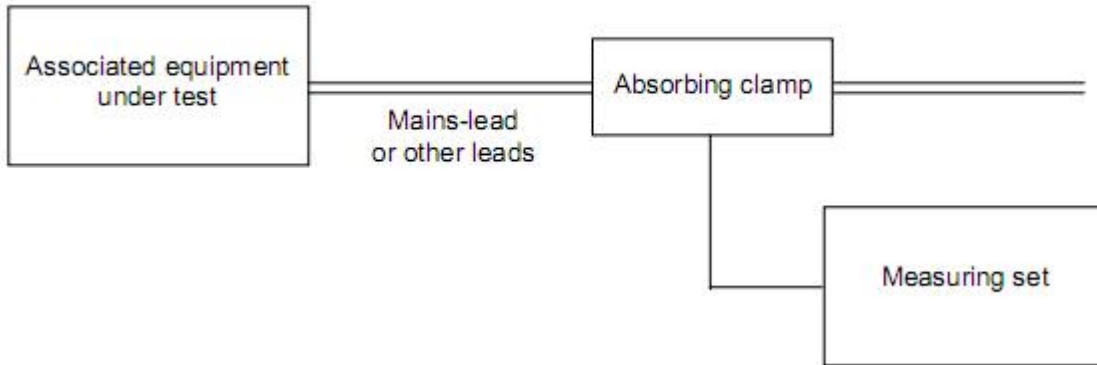

3.2.6 EUT OPERATING CONDITIONS

The EUT tested system was configured as the statements of 3.1.6 Unless otherwise a special operating condition is specified in the follows during the testing.

**3.2.7 TEST RESULTS**

EUT:	Deodorant Cat Litter Box	Model No. :	SH2116
Temperature:	23.5°C	Relative Humidity:	52.6%
Pressure:	1009 hPa	Test Power :	AC 230V/50Hz
Test Mode :	Max power,Min power		

Remark :

- (1) Reading in which marked as QP means measurements by using Quasi-Peak Detector ,and AV means measurements by using Average Detector.
- (2) All readings are QP Mode value unless otherwise stated AVG in column of 『Note』 . If the QP Mode Measured value compliance with the QP Limits and lower than AVG Limits,the EUT shall be deemed to meet both QP & AVG Limits and then only QP Mode was measured, but AVG Mode didn't perform. In this case, a “ * ” marked in AVG Mode column of Interference Voltage Measured.
- (3) Measuring frequency range from 30MHz to 300MHz.

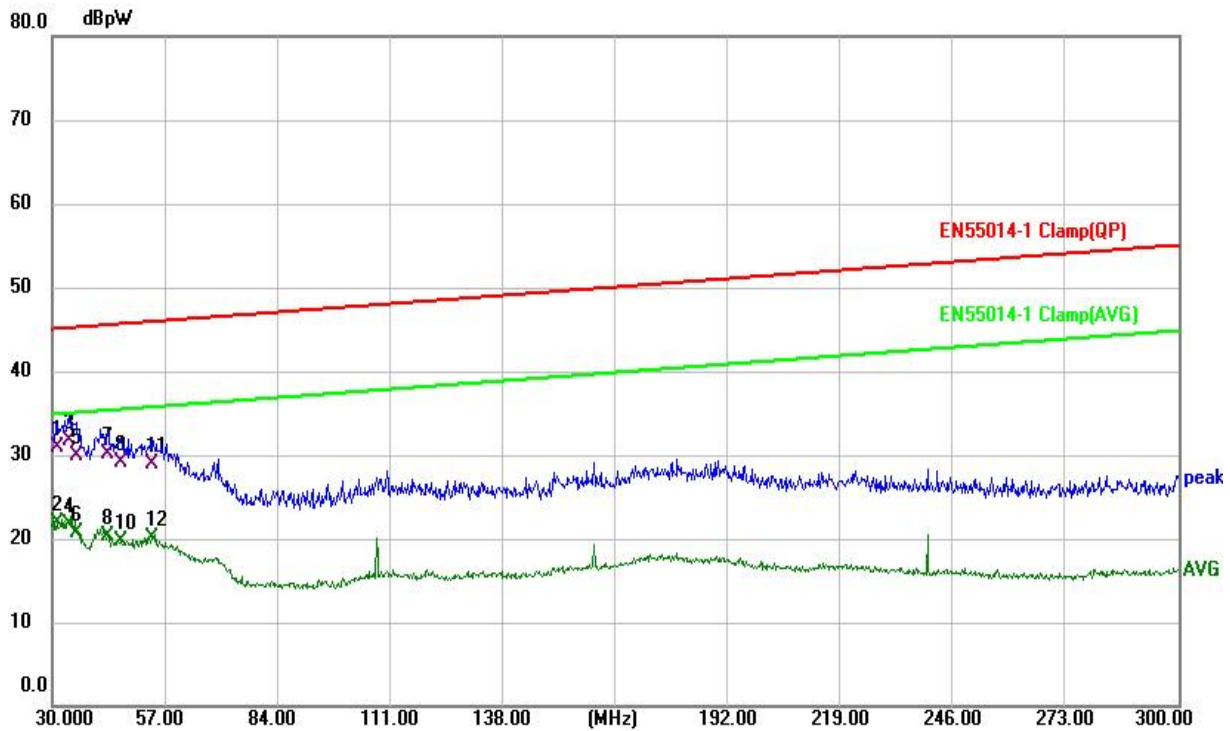

Site:	843.3	Temperature(C):	23.5(C)
Limit:	EN IEC 55014-1 Clamp(QP)	Humidity(%):	52.6%
EUT:	Deodorant Cat Litter Box	Test Time:	2022-06-06
M/N.:	SH2116	Power Rating:	AC 230V/50Hz
Mode:	Min power	Test Engineer:	Luffy
Note:	AC Line		

No.	Frequency (MHz)	Reading Level(dBpW)	Factor (dB)	Measurement(dBpW)	Limit (dBpW)	Over (dB)	Detector	Comment
1	31.2800	21.12	9.83	30.95	45.05	-14.10	QP	
2 *	31.2800	12.07	9.83	21.90	35.05	-13.15	AVG	
3	34.2000	21.92	9.78	31.70	45.16	-13.46	QP	
4	34.2000	12.00	9.78	21.78	35.16	-13.38	AVG	
5	35.9600	20.37	9.58	29.95	45.22	-15.27	QP	
6	35.9600	11.17	9.58	20.75	35.22	-14.47	AVG	
7	43.2400	20.98	9.13	30.11	45.49	-15.38	QP	
8	43.2400	11.15	9.13	20.28	35.49	-15.21	AVG	
9	46.7200	19.78	9.38	29.16	45.62	-16.46	QP	
10	46.7200	10.27	9.38	19.65	35.62	-15.97	AVG	
11	54.0000	19.51	9.43	28.94	45.89	-16.95	QP	
12	54.0000	10.66	9.43	20.09	35.89	-15.80	AVG	

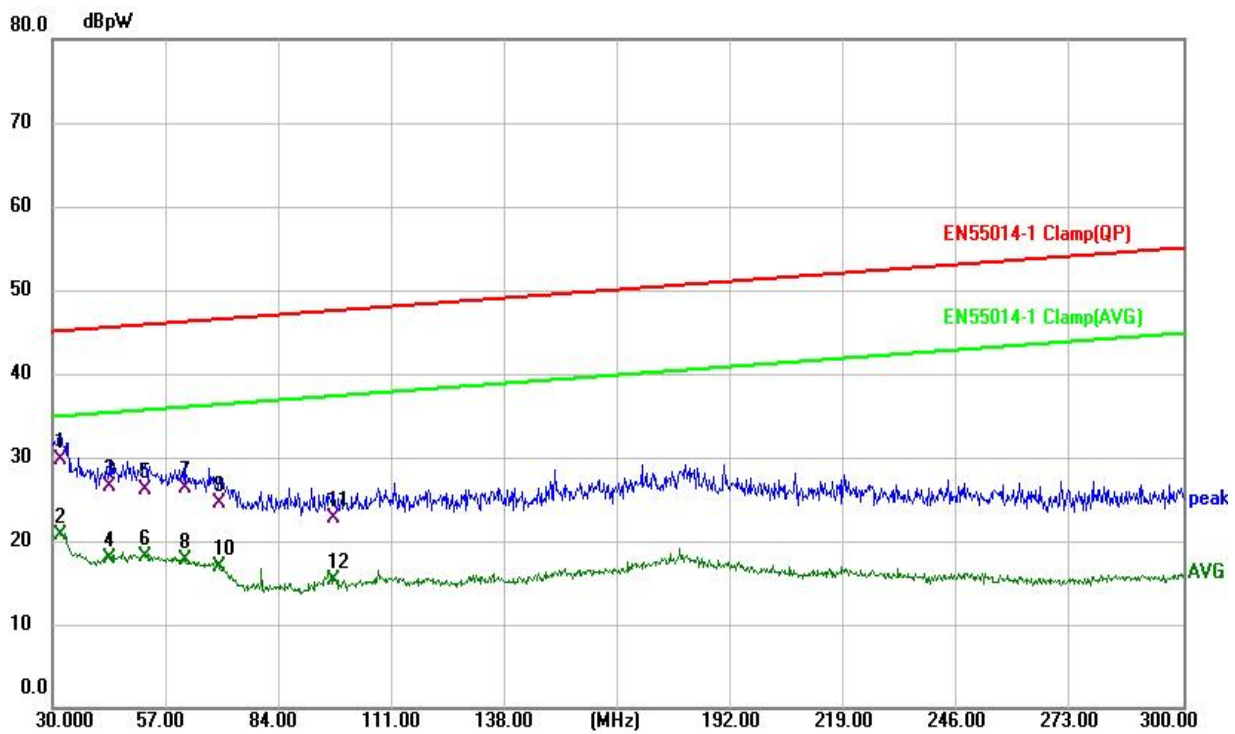

Site:	843.3	Temperature(C):	23.5(C)
Limit:	EN IEC 55014-1 Clamp(QP)	Humidity(%):	52.6%
EUT:	Deodorant Cat Litter Box	Test Time:	2022-06-06
M/N.:	SH2116	Power Rating:	AC 230V/50Hz
Mode:	Min power	Test Engineer:	Luffy
Note:	DC Line		

No.	Frequency (MHz)	Reading Level(dBpW)	Factor (dB)	Measurement(dBpW)	Limit (dBpW)	Over (dB)	Detector	Comment
1	31.9600	19.98	9.82	29.80	45.07	-15.27	QP	
2 *	31.9600	10.85	9.82	20.67	35.07	-14.40	AVG	
3	43.8000	17.30	9.18	26.48	45.51	-19.03	QP	
4	43.8000	8.75	9.18	17.93	35.51	-17.58	AVG	
5	52.2800	16.59	9.47	26.06	45.83	-19.77	QP	
6	52.2800	8.72	9.47	18.19	35.83	-17.64	AVG	
7	61.6000	17.32	9.06	26.38	46.17	-19.79	QP	
8	61.6000	8.69	9.06	17.75	36.17	-18.42	AVG	
9	69.8800	15.82	8.76	24.58	46.48	-21.90	QP	
10	69.8800	8.19	8.76	16.95	36.48	-19.53	AVG	
11	97.3200	16.25	6.51	22.76	47.49	-24.73	QP	
12	97.3200	8.87	6.51	15.38	37.49	-22.11	AVG	

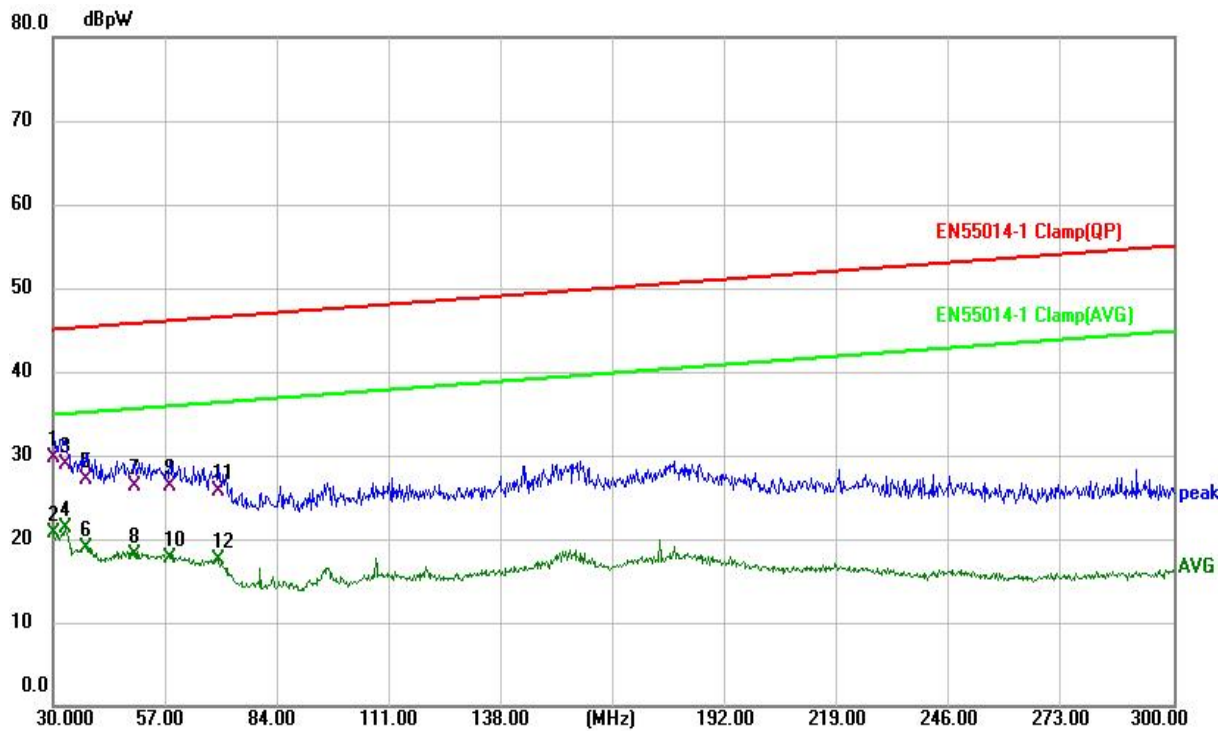

Site:	843.3	Temperature(C):	23.5(C)
Limit:	EN IEC 55014-1 Clamp(QP)	Humidity(%):	52.6%
EUT:	Deodorant Cat Litter Box	Test Time:	2022-06-06
M/N.:	SH2116	Power Rating:	AC 230V/50Hz
Mode:	Max power	Test Engineer:	Luffy
Note:	DC Line		

No.	Frequency (MHz)	Reading Level(dBpW)	Factor (dB)	Measurement(dBpW)	Limit (dBpW)	Over (dB)	Detector	Comment
1	30.3600	19.94	9.85	29.79	45.01	-15.22	QP	
2 *	30.3600	10.79	9.85	20.64	35.01	-14.37	AVG	
3	33.0400	19.11	9.80	28.91	45.11	-16.20	QP	
4	33.0400	11.59	9.80	21.39	35.11	-13.72	AVG	
5	38.0400	17.89	9.17	27.06	45.30	-18.24	QP	
6	38.0400	9.78	9.17	18.95	35.30	-16.35	AVG	
7	49.8800	16.77	9.53	26.30	45.74	-19.44	QP	
8	49.8800	8.61	9.53	18.14	35.74	-17.60	AVG	
9	58.3200	16.91	9.32	26.23	46.05	-19.82	QP	
10	58.3200	8.41	9.32	17.73	36.05	-18.32	AVG	
11	70.0000	16.88	8.76	25.64	46.48	-20.84	QP	
12	70.0000	8.76	8.76	17.52	36.48	-18.96	AVG	

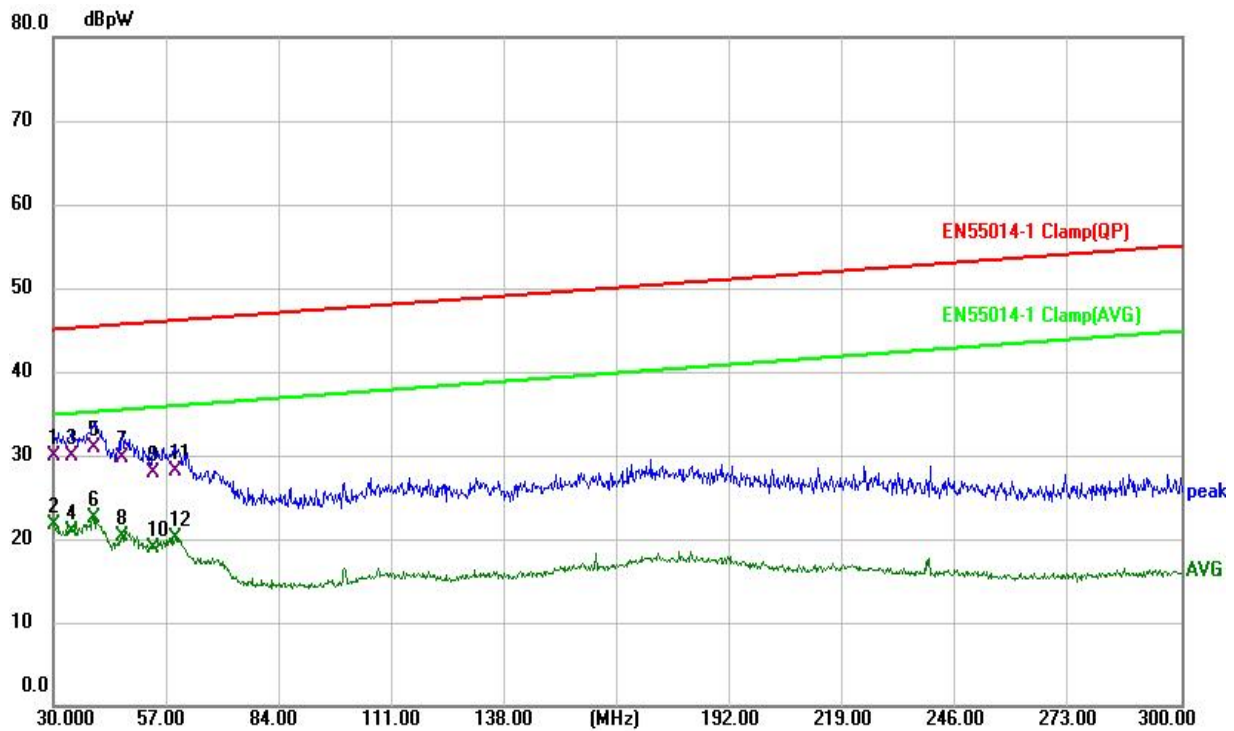

Site:	843.3	Temperature(C):	23.5(C)
Limit:	EN IEC 55014-1 Clamp(QP)	Humidity(%):	52.6%
EUT:	Deodorant Cat Litter Box	Test Time:	2022-06-06
M/N.:	SH2116	Power Rating:	AC 230V/50Hz
Mode:	Max power	Test Engineer:	Luffy
Note:	AC Line		

No.	Frequency (MHz)	Reading Level(dBpW)	Factor (dB)	Measurement(dBpW)	Limit (dBpW)	Over (dB)	Detector	Comment
1	30.0000	20.09	9.85	29.94	45.00	-15.06	QP	
2 *	30.0000	11.81	9.85	21.66	35.00	-13.34	AVG	
3	34.4400	20.17	9.78	29.95	45.16	-15.21	QP	
4	34.4400	11.06	9.78	20.84	35.16	-14.32	AVG	
5	39.9600	22.13	8.80	30.93	45.37	-14.44	QP	
6	39.9600	13.70	8.80	22.50	35.37	-12.87	AVG	
7	46.7200	20.41	9.38	29.79	45.62	-15.83	QP	
8	46.7200	10.91	9.38	20.29	35.62	-15.33	AVG	
9	54.0000	18.53	9.43	27.96	45.89	-17.93	QP	
10	54.0000	9.46	9.43	18.89	35.89	-17.00	AVG	
11	59.2400	18.85	9.30	28.15	46.08	-17.93	QP	
12	59.2400	10.75	9.30	20.05	36.08	-16.03	AVG	

3.3 HARMONICS CURRENT MEASUREMENT

3.3.1 LIMITS OF HARMONICS CURRENT MEASUREMENT

Table 1 – Limits for Class A equipment

Harmonic order n	Maximum permissible harmonic current A
Odd harmonics	
3	2,30
5	1,14
7	0,77
9	0,40
11	0,33
13	0,21
$15 \leq n \leq 39$	$0,15 \frac{15}{n}$
Even harmonics	
2	1,08
4	0,43
6	0,30
$8 \leq n \leq 40$	$0,23 \frac{8}{n}$

Table 2 – Limits for Class C equipment ^a

Harmonic order h	Maximum permissible harmonic current expressed as a percentage of the input current at the fundamental frequency %
2	2
3	$\left[A_1 \right] 27^b \left[A_2 \right]$
5	10
7	7
9	5
$11 \leq h \leq 39$ (odd harmonics only)	3

^a For some Class C products, other emission limits apply (see 7.4).

$\left[A_1 \right]$ ^b The limit is determined based on the assumption of modern lighting technologies having power factors of 0,90 or higher. $\left[A_2 \right]$

Table 3 – Limits for Class D equipment

Harmonic order n	Maximum permissible harmonic current per watt mA/W	Maximum permissible harmonic current A
3	3,4	2,30
5	1,9	1,14
7	1,0	0,77
9	0,5	0,40
11	0,35	0,33
$13 \leq n \leq 39$ (odd harmonics only)	$\frac{3,85}{n}$	See Table 1

3.3.2 MEASUREMENT INSTRUMENTS LIST

Item	Kind of Equipment	Manufacturer	Type No.	Serial No.	Calibrated until
1	Harmonic and Flicker Analyzer	EMC PARTNER	Harmonics 1000-1P 230V	0241	2023-05-12

Remark: " N/A" denotes No Model No. / Serial No. and No Calibration specified.

3.3.3 TEST PROCEDURE

- a. Test was performed according to the procedures specified in Clause 5.0 of IEC555-2 and/or Sub-clause 6.2 of IEC/EN 61000-3-2 depend on which standard adopted for compliance measurement.
- b. All types of harmonic current and/or voltage fluctuation in this report are assessed by direct measurement using flicker-meter.
- c. For the actual test configuration, please refer to the related Item –EUT Test Photos.

3.3.4 DEVIATION FROM TEST STANDARD

No deviation

3.3.5 TEST SETUP

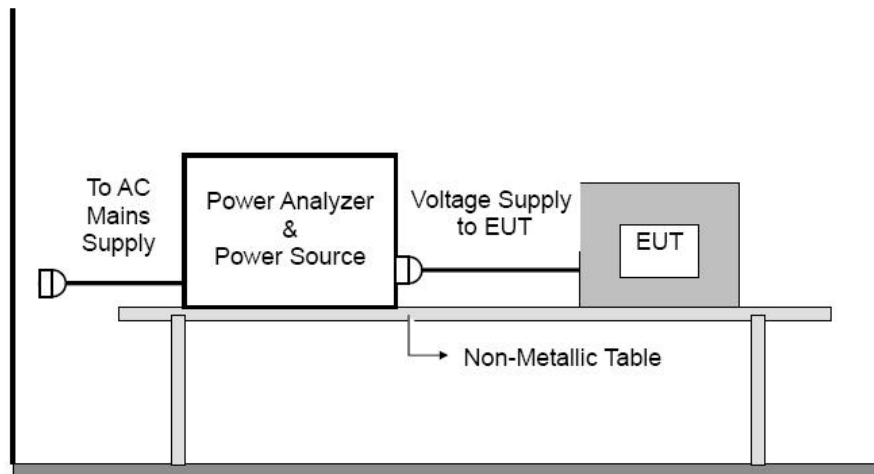

3.3.6 EUT OPERATING CONDITIONS

The EUT tested system was configured as the statements of 3.1.6 Unless otherwise a special operating condition is specified in the follows during the testing.

3.3.7 TEST RESULTS

According to clause 7.0 of EN 61000-3-2, for the equipment with a rate power of 75W or less, limits are not specified in this standard.

3.4 VOLTAGE FLUCTUATION AND FLICKS MEASUREMENT

3.4.1 LIMITS OF VOLTAGE FLUCTUATION AND FLICKS MEASUREMENT

Tests	Limits		Descriptions
	IEC555-3	IEC/EN 61000-3-2	
Pst	≤ 1.0, Tp= 10 min.	≤ 1.0, Tp= 10 min.	Short Term Flicker Indicator
Plt	N/A	≤ 0.65, Tp=2 hr.	Long Term Flicker Indicator
dc	≤ 3 %	≤ 3.3 %	Relative Steady-State V-Chang
dmax	≤ 4 %	≤ 4 %	Maximum Relative V-change
d (t)	N/A	≤ 3.3% for > 500 ms	Relative V-change characteristic

3.4.2 MEASUREMENT INSTRUMENTS LIST

Item	Kind of Equipment	Manufacturer	Type No.	Serial No.	Calibrated until
1	Harmonic and Flicker Analyzer	EMC PARTNER	Harmonics 1000-1P 230V	0241	2023-05-12

Remark: " N/A" denotes No Model No. / Serial No. and No Calibration specified.

3.4.3 TEST PROCEDURE

- Tests was performed according to the Test Conditions/Assessment of Voltage Fluctuations specified in Clause 5.0/6.0 of IEC555-3 and/or Clause 6.0/4.0 of IEC/EN 61000-3-3 depend on which standard adopted for compliance measurement.
- All types of harmonic current and/or voltage fluctuation in this report are assessed by direct measurement using flicker-meter.
- For the actual test configuration, please refer to the related Item –EUT Test Photos.

3.4.4 DEVIATION FROM TEST STANDARD

No deviation

3.4.5 TEST SETUP

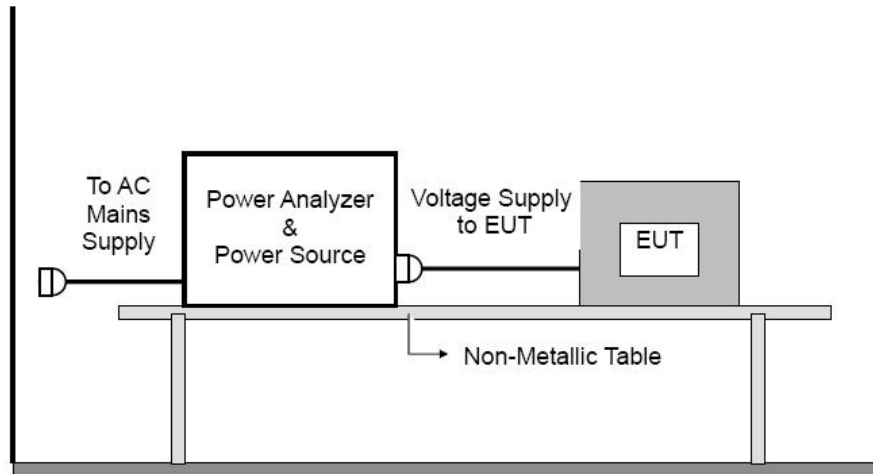

3.4.6 EUT OPERATING CONDITIONS

The EUT tested system was configured as the statements of 3.1.6 Unless otherwise a special operating condition is specified in the follows during the testing.



3.4.7 TEST RESULTS

EUT:	Deodorant Cat Litter Box	Model No. :	SH2116
Temperature:	22°C	Relative Humidity:	55%
Pressure:	1009 hPa	Test Power :	AC 230V/50Hz
Test Mode :	Max power		

Flicker Emission - IEC 61000-3-3, EN 61000-3-3

Flicker Emission IEC 61000-4-15 for 230V/50Hz

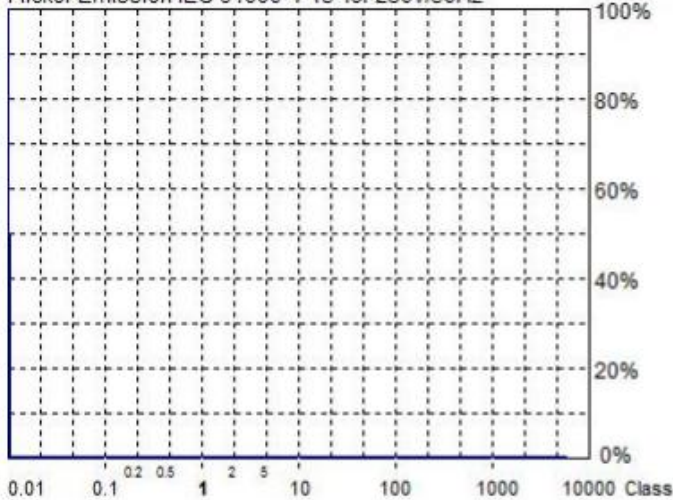

Actual Flicker (Fli):	0.00
Short-term Flicker (Pst):	0.07
Limit (Pst):	1.00
Long-term Flicker (Plt):	0.07
Limit (Plt):	0.65
Maximum Relative Volt. Change (dmax):	0.00%
Limit (dmax):	4.00%
Relative Steady-state Voltage Change (dc):	0.00%
Limit (dc):	3.30%
Tmax 3.30% (dt):	0.00ms
Limit (dt>Lim):	500ms

Flicker Emission - IEC 61000-3-3, EN 61000-3-3

Urms = 230.1 V P = 3.350 W
 Irms = 0.032 A pf = 0.457

2022/6/9 17:29:36

Range: Auto
 V-nom: 230 V
 TestTime: 10 min (100%)

Test completed, Result: PASSED

HAR-1000 EMC-Partner

Urms = 230.1V Freq = 50.039 Range: 0.25 A
 Irms = 0.032A Ipk = 0.163A cf = 5.103
 P = 3.350W S = 7.331VA pf = 0.457

Test - Time : 1 x 10min = 10min (100 %)

LIN (Line Impedance Network) : L: 0.24ohm +j0.15ohm N: 0.16ohm +j0.10ohm

Limits : Plt : 0.65 Pst : 1.00
 dmax : 4.00 % dc : 3.30 %
 dtLim: 3.30 % dt>Lim: 500ms

Test completed, Result: PASSED

4. IMMUNITY TEST

4.1 STANDARD COMPLIANCE/SERVRITY LEVEL/CRITERIA

Tests Standard No.	TEST SPECIFICATION Level	Test Mode Test Ports	Perform. Criteria	Remark
1. ESD IEC/EN 61000-4-2	8KV air discharge 4KV contact discharge	Direct Mode	B	PASS
	4KV HCP discharge 4KV VCP discharge	Indirect Mode	B	PASS
2. RS IEC/EN 61000-4-3	80 MHz to 1000 MHz 3V/m(rms), 1 KHz, 80%, AM modulated	Enclosure	A	N/A
3. EFT/Burst IEC/EN 61000-4-4	1.0KV(peak) 5/50ns Tr/Th 5KHz Repetition Freq.	AC Power Port	B	PASS
	0.5 KV(peak) 5/50ns Tr/Th 5KHz Repetition Freq.	CTL/Signal Data Line Port	B	N/A
4. Surges IEC/EN 61000-4-5	1 KV(5P/5N) 1.2/50(8/20) Tr/Th us	L-N	B	PASS
	2 KV(5P/5N) 1.2/50(8/20) Tr/Th us	L-PE N-PE	B	N/A
5 Injected Current IEC/EN 61000-4-6	0.15 MHz to 230 MHz 1V(rms), 1KHz 80%, AM Modulated 150Ω source impedance	CTL/Signal Port	A	N/A
	0.15 MHz to 230 MHz 3V(rms), 1KHz 80%, AM Modulated 150Ω source impedance	AC Power Port	A	PASS
	0.15 MHz to 230 MHz 1V(rms), 1KHz 80%, AM Modulated 150Ω source impedance	DC Power Port	A	N/A

<p>6 Volt. Interruptions Volt. Dips IEC/EN 61000-4-11</p>	<p>Voltage Dips: AC Line 100/240V, 50Hz i) 30% reduction for 25 period, Performance Criterion C ii) 60% reduction for 10 period, Performance Criterion C</p> <p>Voltage Interruptions: 100% reduction for 0.5 period Performance Criterion C</p> <p>Voltage Dips: AC Line 100/240V, 60Hz i) 30% reduction for 30 period, Performance Criterion C ii) 60% reduction for 12 period, Performance Criterion C</p> <p>Voltage Interruptions: 100% reduction for 0.5 period Performance Criterion C</p>	<p>AC Power Port</p>	<p>C</p>	<p>PASS</p>
---	---	----------------------	----------	-------------

* Remark:

(1) "N/A": denotes test is not applicable in this Test Report.
(2)ESD test was carried out in ESD room.
(3)Other test was carried out in EMS room.

4.2 GENERAL PERFORMANCE CRITERIA

According to **EN IEC 55014-2:2021** standard, the general performance criteria as following:

Criterion A	The equipment shall continue to operate as intended without operator intervention. No degradation of performance or loss of function is allowed below a performance level specified by the manufacturer when the equipment is used as intended. The performance level may be replaced by a permissible loss of performance. If the minimum performance level or the permissible performance loss is not specified by the manufacturer, then either of these may be derived from the product description and documentation, and by what the user product description and documentation, and by what the user may reasonably expect from the equipment if used as intended.
Criterion B	After the test, the equipment shall continue to operate as intended without operator Intervention. No degradation of performance or loss of function is allowed, after the application of the phenomenon below a performance level specified by the manufacturer, when the equipment is used as intended. The performance level may be replaced by a permissible loss of performance. During the test, degradation of performance is allowed. However, no change of operating state if stored data allowed to persist after the test. If the minimum performance level (or the permissible performance loss) is not specified by the manufacturer, then either of these may be derived from the product description and documentation, and by what the user may reasonably expect from the equipment if used as intended.
Criterion C	Loss of function is allowed, provided the function is self-recoverable, or can be restored by the operation of the controls by the user in accordance with the manufacturer's instructions. Functions, and/or information stored in non-volatile memory, or protected by a battery backup, shall not be lost.

4.3 GENERAL PERFORMANCE CRITERIA TEST SETUP

The EUT tested system was configured as the statements of **3.1.6** Unless otherwise a special operating condition is specified in the follows during the testing.

4.4 ESD TESTING

4.4.1 TEST SPECIFICATION

Basic Standard:	IEC/EN 61000-4-2
Discharge Impedance:	330 ohm / 150 pF
Required Performance	B
Discharge Voltage:	Air Discharge: 2kV/4kV/8kV/15kV (Direct) Contact Discharge: 2kV/4kV/6kV/8kV (Direct/Indirect)
Polarity:	Positive & Negative
Number of Discharge:	Air Discharge: 10 times at each test point Contact Discharge: min. 200 times in total
Discharge Mode:	Contact and Air
Discharge Period:	1 second minimum

4.4.2 MEASUREMENT INSTRUMENTS

Item	Instr.Code	Kind of Equipment	Manufacturer	Type No.	Serial No.	Calibrated until
1	AN-E002	ESD Simulator	TESEQ	NSG437	336	2023-05-23

Remark: " N/A " denotes No Model No. / Serial No. and No Calibration specified.

4.4.3 TEST PROCEDURE

The test generator necessary to perform direct and indirect application of discharges to the EUT in the following manner:

- a. Contact discharge was applied to conductive surfaces and coupling planes of the EUT. During the test, it was performed with single discharges. For the single discharge time between successive single discharges was at least 1 second. The EUT shall be exposed to at least 200 discharges, 100 each at negative and positive polarity, at a minimum of four test points. One of the test points shall be subjected to at least 50 indirect discharges to the center of the front edge of the horizontal coupling plane. The remaining three test points shall each receive at least 50 direct contact discharges.
If no direct contact test points are available, then at least 200 indirect discharges shall be applied in the indirect mode. Test shall be performed at a maximum repetition rate of one discharge per second.
Vertical Coupling Plane (VCP):
The coupling plane, of dimensions 0.5m x 0.5m, is placed parallel to, and positioned at a distance 0.1m from, the EUT, with the Discharge Electrode touching the coupling plane.
The four faces of the EUT will be performed with electrostatic discharge.
Horizontal Coupling Plane (HCP):
The coupling plane is placed under to the EUT. The generator shall be positioned vertically at a distance of 0.1m from the EUT, with the Discharge Electrode touching the coupling plane.
The four faces of the EUT will be performed with electrostatic discharge.
- b. Air discharges at insulation surfaces of the EUT.
It was at least ten single discharges with positive and negative at the same selected point.
- c. For the actual test configuration, please refer to the related Item –EUT Test Photos.

4.4.4 DEVIATION FROM TEST STANDARD

No deviation

4.4.5 TEST SETUP

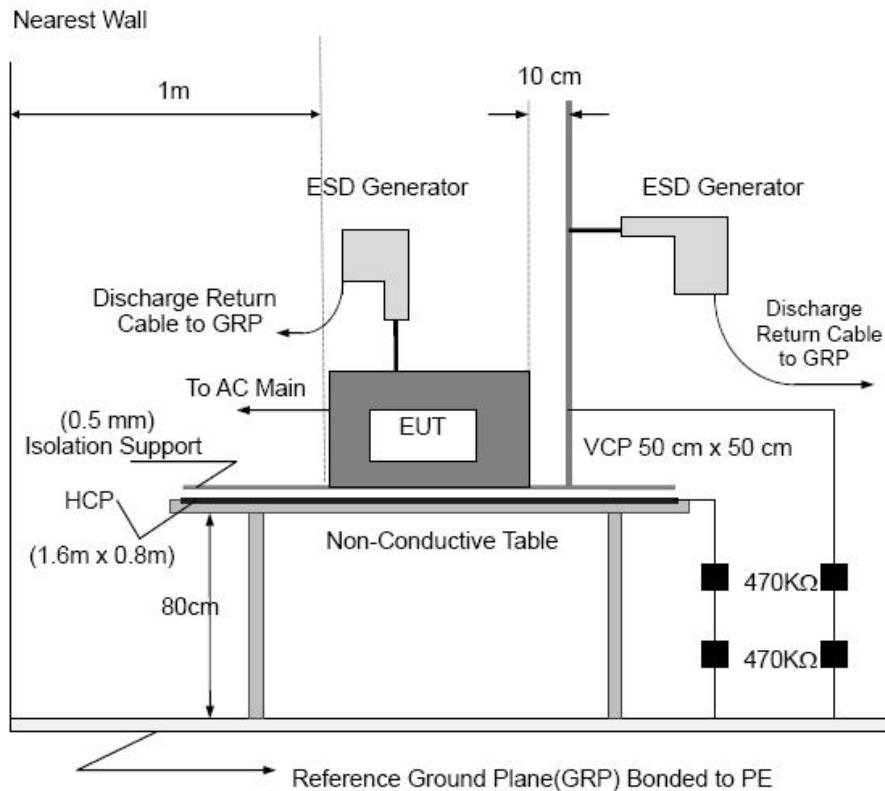

Note:

TABLE-TOP EQUIPMENT

The configuration consisted of a wooden table 0.8 meters high standing on the Ground Reference Plane. The GRP consisted of a sheet of aluminum at least 0.25mm thick, and 2.5 meters square connected to the protective grounding system. A Horizontal Coupling Plane (1.6m x 0.8m) was placed on the table and attached to the GRP by means of a cable with 940k total impedance. The equipment under test, was installed in a representative system as described in section 7 of IEC /EN 61000-4-2, and its cables were placed on the HCP and isolated by an insulating support of 0.5mm thickness. A distance of 1-meter minimum was provided between the EUT and the walls of the laboratory and any other metallic structure.

FLOOR-STANDING EQUIPMENT

The equipment under test was installed in a representative system as described in section 7 of IEC/EN 61000-4-2, and its cables were isolated from the Ground Reference Plane by an insulating support of 0.1-meter thickness. The GRP consisted of a sheet of aluminum that is at least 0.25mm thick, and 2.5 meters square connected to the protective grounding system and extended at least 0.5 meters from the EUT on all sides.



4.4.6 TEST RESULTS

Mode	Air Discharge								Contact Discharge							
	2KV		4KV		8KV		15KV		2KV		4KV		6KV		8KV	
Location	P	N	P	N	P	N	P	N	P	N	P	N	P	N	P	N
1	--	--	A	A	A	A		--					--	--	--	--
2	--	--	A	A	A	A		--					--	--	--	--
3	-	--						--	--	--	--	--	--	--	--	--
4	--	--	--	--	--	--	--	--	--	--			--	--	--	--
5	--	--	--	--	--	--	--	--	--	--	--	--	--	--	--	--
6	-	--	--	--	--	--	--	--	--	--	--	--	--	--	--	--
7	--	--	--	--	--	--	--	--	--	--	--	--	--	--	--	--
8	--	--	--	--	-	--	--	--	--	--	--	--	--	--	--	--
9	--	--	--	--	-	--	--	--	--	--	--	--	--	--	--	--
Criteria	B															
Result	A															
Judgment	PASS															

Mode	HCP Discharge								VCP Discharge							
	2KV		4KV		6KV		8KV		2KV		4KV		6KV		8KV	
Location	P	N	P	N	P	N	P	N	P	N	P	N	P	N	P	N
1	-	--	A	A	--	--	--	--	-	--	A	A	--	--	--	--
2	--	--	A	A	--	--	--	--	--	--	A	A	--	--	--	--
3	--	--	A	A	-	--	--	--	--	--	A	A	-	--	--	--
4	-	--	A	A	--	--	--	--	-	--	A	A	--	--	--	--
Criteria	B								B							
Result	A								A							
Judgment	PASS								PASS							

Note:

- 1) P/N denotes the Positive/Negative polarity of the output voltage.
- 2) Test condition:
Direct discharges: Minimum 50 times (Positive/Negative) at eachpoint.Air discharges / Indirect (HCP/VCP): Minimum 20 times (Positive/Negative) at each point.
- 3) Test location(s) in which discharge (Air and contact discharge) to be described as following
- 4) The Indirect (HCP/VCP) discharges description of test point as following:
1.left side 2.right side 3.front side 4.rear side
- 5) N/A - denotes test is not applicable in this test report
- 7) Criteria B: The EUT function loss during the test, but self-recoverable after the test.

Test location description:

No	Description	No	Description
1	Input port1 point	3	
2	Gaps 6 points	4	

4.5 RS TESTING

4.5.1 TEST SPECIFICATION

Basic Standard:	IEC/EN 61000-4-3
Required Performance	A
Frequency Range:	80 MHz - 1000 MHz
Field Strength:	3 V/m
Modulation:	1kHz Sine Wave, 80%, AM Modulation
Frequency Step:	1 % of fundamental
Polarity of Antenna:	Horizontal and Vertical
Test Distance:	3 m
Antenna Height:	1.5 m
Dwell Time:	at least 3 seconds

4.5.2 MEASUREMENT INSTRUMENTS

Equipment	Manufacturer	Model No.	Serial No.	Next Cal.
Signal Generator	Agilent	N5171B-50B	MY53050160	2022-11-29
Amplifier	A&R	150W1000M3	313157	2022-08-25
Amplifier	A&R	50SIG6M1	0342835	2022-08-25
Power Meter	Boonton	4232A	15102	2022-08-11
Isotropic Field Probe	A&R	FL7006	0342652	2022-10-24
Log-periodic Antenna	SCHWARZBECK	STLP 9128E	9128E-012	2022-12-10
Microwave log-periodic antenna	SCHWARZBECK	STLP 9149	9149.222	2022-12-10

Remark: " N/A" denotes No Model No. / Serial No. and No Calibration specified.

4.5.3 TEST PROCEDURE

The EUT and support equipment, which are placed on a table that is 0.8 meter above ground and the testing was performed in a fully-echoic chamber.

The testing distance from antenna to the EUT was 3 meters.

The other condition as following manner:

- a. The field strength level was 3V/m.
- b. The frequency range is swept from 80 MHz to 1000 MHz, with the signal 80%amplitude modulated with a 1kHz sine wave. The rate of sweep did not exceed 1.5x 10⁻³ decade/s. Where the frequency range is swept incrementally, the step size was 1% of fundamental.
- c. The dwell time at each frequency shall be not less than the time necessary for the EUT to be able to respond.
- d. The test was performed with the EUT exposed to both vertically and horizontally polarized fields on each of the four sides.
- e. For the actual test configuration, please refer to the related Item –EUT Test Photos.

4.5.4 DEVIATION FROM TEST STANDARD

No deviation

4.5.5 TEST SETUP

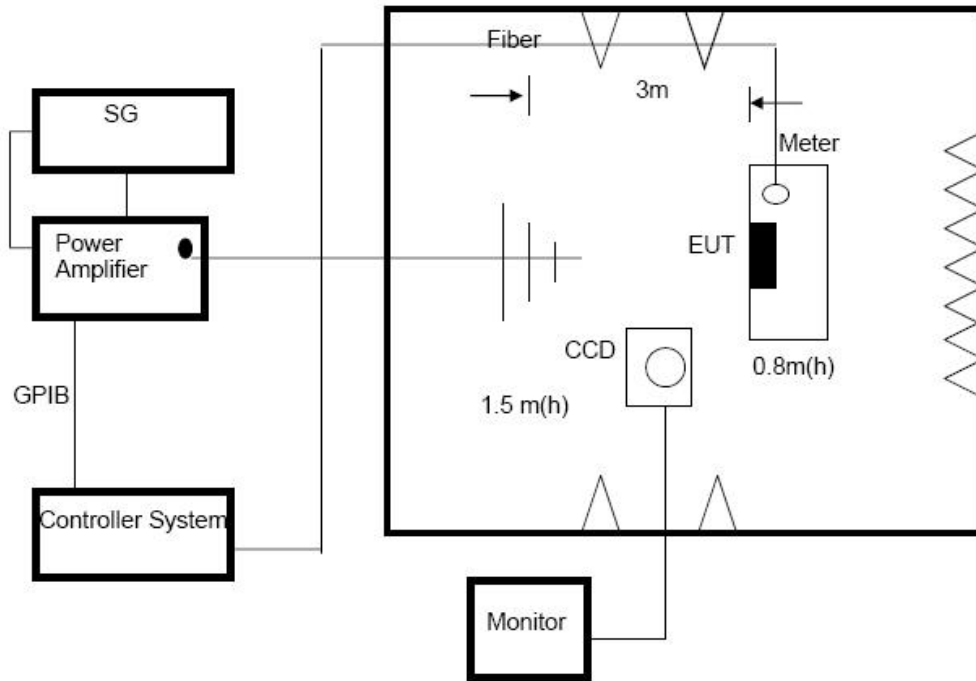

Note:

TABLE-TOP EQUIPMENT

The EUT installed in a representative system as described in section 7 of IEC/EN 61000-4-3 was placed on a non-conductive table 0.8 meters in height. The system under test was connected to the power and signal wire according to relevant installation instructions.

FLOOR-STANDING EQUIPMENT

The EUT installed in a representative system as described in section 7 of IEC/EN 61000-4-3 was placed on a non-conductive wood support 0.1 meters in height. The system under test was connected to the power and signal wire according to relevant installation instructions.

4.5.6 TEST RESULTS

This product belong to Catalog II equipment, so no applicable.

4.6 EFT/BURST TESTING

4.6.1 TEST SPECIFICATION

Basic Standard:	IEC/EN 61000-4-4
Required Performance	B
Test Voltage:	Power Line: ± 1 kV
Polarity:	Positive & Negative
Impulse Frequency:	5 kHz
Impulse Wave shape :	5/50 ns
Burst Duration:	15 ms
Burst Period:	300 ms
Test Duration:	Not less than 1 min.

4.6.2 MEASUREMENT INSTRUMENTS

Item	Kind of Equipment	Manufacturer	Type No.	Serial No.	Calibrated until
1	Electrical Intelligent Transient Generator	Everfine	EMS61000-4B	G114921CA134 1115	2023-05-12

Remark: " N/A" denotes No Model No. / Serial No. and No Calibration specified.

4.6.3 TEST PROCEDURE

The EUT and support equipment, are placed on a table that is 0.8 meter above a metal ground plane measured 1m*1m min. and 0.65mm thick min.

The other condition as following manner:

- a. The length of power cord between the coupling device and the EUT should not exceed 1 meter.
- b. Both positive and negative polarity discharges were applied.
- c. The duration time of each test sequential was 1 minute
- d. For the actual test configuration, please refer to the related Item –EUT Test Photos.

4.6.4 DEVIATION FROM TEST STANDARD

No deviation

4.6.5 TEST SETUP

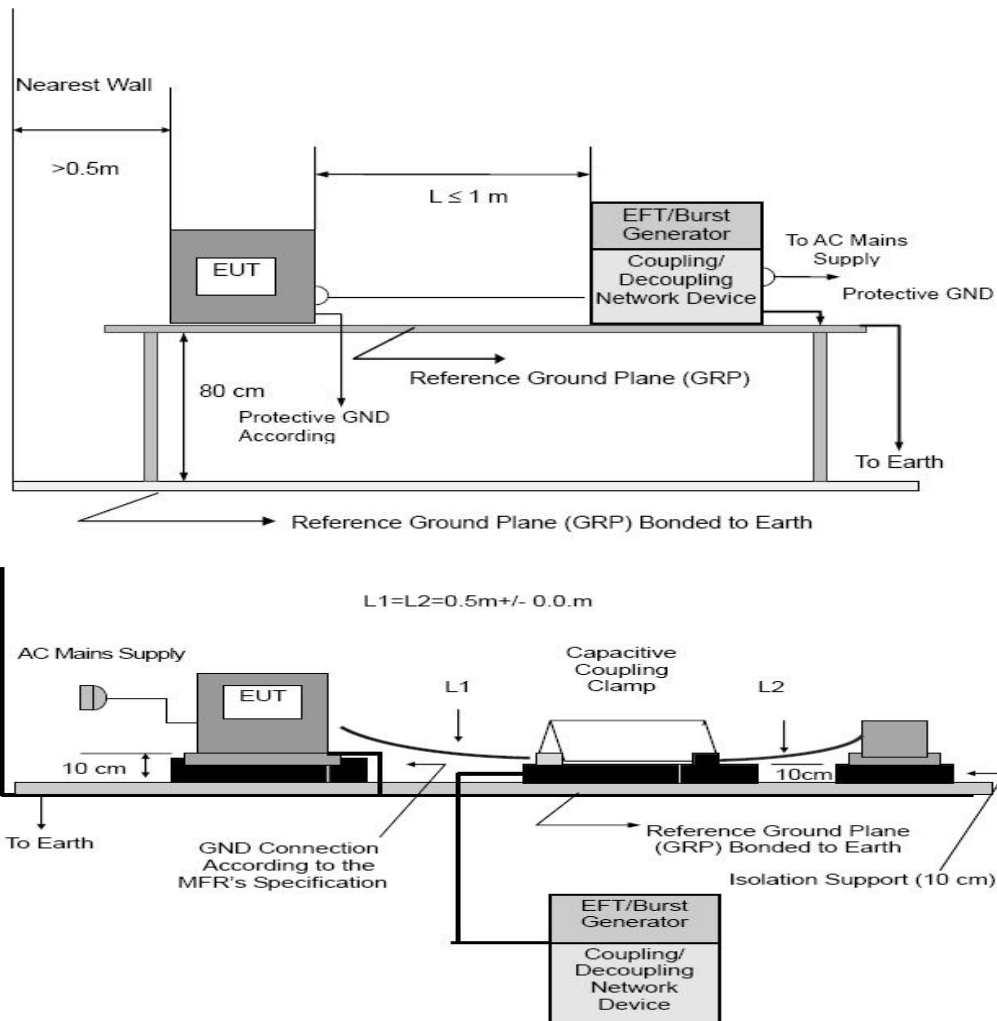

Note:

TABLE-TOP EQUIPMENT

The configuration consisted of a wooden table (0.8m high) standing on the Ground Reference Plane. The GRP consisted of a sheet of aluminum (at least 0.25mm thick and 2.5m square) connected to the protective grounding system. A minimum distance of 0.5m was provided between the EUT and the walls of the laboratory or any other metallic structure.

FLOOR-STANDING EQUIPMENT

The EUT installed in a representative system as described in section 7 of IEC/EN 61000-4-4 and its cables, were isolated from the Ground Reference Plane by an insulating support that is 0.1-meter thick. The GRP consisted of a sheet of aluminum (at least 0.25mm thick and 2.5m square) connected to the protective grounding system.

4.6.6 TEST RESULTS

Mode	AC Power Line		DC Power Line		Signal/Control Line	
Test Level	1KV		0.5KV		0.5KV	
Port(s)	Polarity	Results	Polarity	Results	Polarity	Results
Line (L)	P	A	P		P	
	N	A	N		N	
Neutral (N)	P	A	P		P	
	N	A	N		N	
Ground (PE)	P		P		P	
	N		N		N	
Signal/Control Line	P		P		P	
	N		N		N	
Criteria	B		B		B	
Result	A		--		--	
Judgment	PASS		N/A		N/A	

- 1) P/N denotes the Positive/Negative polarity of the output voltage.
- 2) N/A - denotes test is not applicable in this test report
- 3) Criteria A: There was no change operated with initial operating during the test.
- 4) Criteria B: The EUT function loss during the test, but self-recoverable after the test.
- 5) Criteria C: The system shut down during the test.

4.7 SURGE TESTING

4.7.1 TEST SPECIFICATION

Basic Standard:	IEC/EN 61000-4-5
Required Performance	B
Wave-Shape:	Combination Wave 1.2/50 us Open Circuit Voltage 8 /20 us Short Circuit Current
Test Voltage:	Power Line: 0.5 kV, 1 kV, 2 kV
Surge Input/Output:	L-N, L-PE, N-PE
Generator Source:	2 ohm between networks
Impedance:	12 ohm between network and ground
Polarity:	Positive/Negative
Phase Angle:	0 /90/180/270
Pulse Repetition Rate:	1 time / min. (maximum)
Number of Tests:	5 positive and 5 negative at selected points

4.7.2 MEASUREMENT INSTRUMENTS

Item	Instr.Code	Kind of Equipment	Manufacturer	Type No.	Serial No.	Calibrated until
1	AN-E054	Immunity Teat System	EMC PARTNER	IMU3000 S-T	105684-2060	2023-05-12
2	AN-E055	Signal line coupled decoupling network	EMC PARTNER	CDN-UTP8 ED3	1558	2023-05-12

Remark: " N/A" denotes No Model No. / Serial No. and No Calibration specified.

4.7.3 TEST PROCEDURE

a. For EUT:

The surge is to be applied to the EUT terminals via the capacitive coupling network. Decoupling networks are required in order to avoid possible adverse effects on equipment not under test that may be powered by the same lines, and to provide sufficient decoupling impedance to the surge wave. The power cord between the EUT and the coupling/decoupling networks shall be 2meters in length (or shorter).

b. For test applied to unshielded unsymmetrically operated interconnection lines of EUT:

The surge is applied to the lines via the capacitive coupling. The coupling /decoupling networks shall not influence the specified functional conditions of the EUT. The interconnection line between the EUT and the coupling/decoupling networks shall be 2 meters in length (or shorter).

c. For test applied to unshielded symmetrically operated interconnection /telecommunication lines of EUT:

The surge is applied to the lines via gas arrestors coupling. Test levels below the ignition point of the coupling arrestor cannot be specified. The interconnection line between the EUT and the coupling/decoupling networks shall be 2 meters in length (or shorter).

d. For the actual test configuration, please refer to the related Item –EUT Test Photos.

4.7.4 DEVIATION FROM TEST STANDARD

No deviation

4.7.5 TEST SETUP

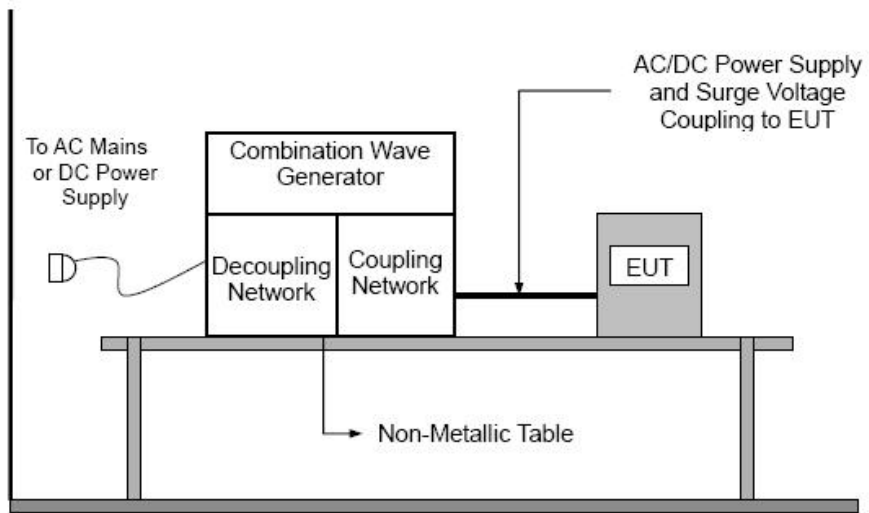

4.7.6 TEST RESULTS

Wave Form EUT Ports Tested	1.2/50(8/20) us						Criteria	Judgment
	Polarity	Phase	Voltage					
			0.5kV	1kV	1.5kV	2kV		
L - N	+/-	0°		B			B	PASS
	+/-	90°		B				
	+/-	180°		B				
	+/-	270°		B				
L - PE	+/-	0°					N/A	N/A
	+/-	90°						
	+/-	180°						
	+/-	270°						
N - PE	+/-	0°					N/A	N/A
	+/-	90°						
	+/-	180°						
	+/-	270°						
Signal Line (N/A)	+/-	0°					N/A	N/A
	+/-	90°						
	+/-	180°						
	+/-	270°						
Signal Line (N/A)	+/-	0°					N/A	N/A
	+/-	90°						
	+/-	180°						
	+/-	270°						

Note:

- 1) N/A - denotes test is not applicable in this Test Report.

4.8 INJECTION CURRENT TESTING

4.8.1 TEST SPECIFICATION

Basic Standard:	IEC/EN 61000-4-6
Required Performance	A
Frequency Range:	0.15 MHz - 80 MHz
Field Strength:	3 Vr.m.s.
Modulation:	1kHz Sine Wave, 80%, AM Modulation
Frequency Step:	1 % of fundamental
Dwell Time:	at least 3 seconds

4.8.2 MEASUREMENT INSTRUMENTS

Item	Kind of Equipment	Manufacturer	Type No.	Serial No.	Calibrated until
1	CONDUCTED IMMUNITY TEST SYSTEM	FRANKONIA	CIT-10	102D1253	2022-07-21
2	CDN	FRANKONIA	CDN M2+M3	A3011059	2022-08-09
3	Electromagnetic clamp	FRANKONIA	KEMZ-801	21044	2022-08-09

Remark: " N/A" denotes No Model No. / Serial No. and No Calibration specified.

4.8.3 TEST PROCEDURE

The EUT and support equipment, are placed on a table that is 0.8 meter above a metal ground plane measured 1m*1m min. and 0.65mm thick min.

The other condition as following manner:

- a. The field strength level was 3V.
- b. The frequency range is swept from 150 KHz to 80 MHz, with the signal 80%amplitude modulated with a 1kHz sine wave. The rate of sweep did not exceed 1.5x 10⁻³ decade/s. Where the frequency range is swept incrementally, the step size was 1% of fundamental.
- c. The dwell time at each frequency shall be not less than the time necessary for the EUT to be able to respond.
- d. For the actual test configuration, please refer to the related Item –EUT Test Photos.

4.8.4 DEVIATION FROM TEST STANDARD

No deviation

4.8.5 TEST SETUP

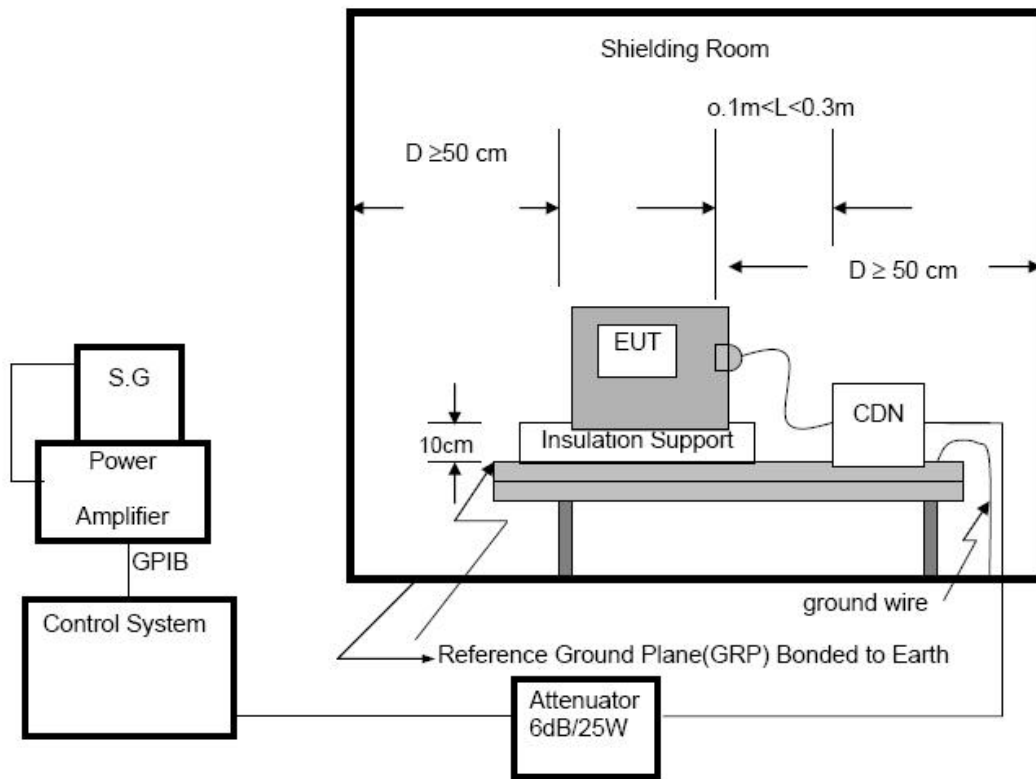

For the actual test configuration, please refer to the related Item –EUT Test Photos.

NOTE:

FLOOR-STANDING EQUIPMENT

The equipment to be tested is placed on an insulating support of 0.1 meters height above a ground reference plane. All relevant cables shall be provided with the appropriate coupling and decoupling devices at a distance between 0.1 meters and 0.3 meters from the projected geometry of the EUT on the ground reference plane.

4.8.6 TEST RESULTS

Test Ports (Mode)	Freq. Range (MHz)	Field Strength	Perform. Criteria	Results	Judgment
Input/ Output AC. Power Port	0.15 ---230	3V(rms) AM Modulated 1000Hz, 80%	A	A	PASS
Input/ Output DC. Power Port	0.15 --- 230	1V(rms) AM Modulated 1000Hz, 80%	A	--	N/A See note 3)
Signal Line	0.15 --- 230		A	--	N/A See note 2)
control lines	0.15 --- 230		A	--	N/A See note 2)

Note:

- 1) N/A - denotes test is not applicable in this Test Report.
- 2) Applicable only to ports interfacing with cables whose total length may exceed 3m according to the manufacturer's function specification.
- 3) Not applicable to battery operated appliances that cannot be connected to the mains while in use. Not applicable to input ports intended for connection to a battery or a rechargeable battery which shall be removed or disconnected from the apparatus for recharging. Apparatus with a d.c. power input port intended for use with an a.c. – d.c. power adaptor shall be tested on the a.c. power input of the a.c.- d.c. power adaptor specified by the manufacturer or, where none is so specified, using a typical a.c. – d.c. power adaptor. For d.c.input and output ports intended to be connected permanently, the test is only applicable to cables longer than3 m.

4.9 VOLTAGE INTERRUPTION/DIPS TESTING

4.9.1 TEST SPECIFICATION

Basic Standard:	IEC/EN 61000-4-11
Required Performance:	C (For 300% Voltage Dips) C (For 60% Voltage Dips) C (For 100% Voltage Interruptions)
Test Duration Time:	Minimum three test events in sequence
Interval between Event:	Minimum ten seconds
Phase Angle:	0°
Test Cycle:	3 times

4.9.2 MEASUREMENT INSTRUMENTS

Item	Kind of Equipment	Manufacturer	Type No.	Serial No.	Calibrated until
1	Voltage Dips And Interruptions Generator	Everfine	EMS61000-11 K	G113317CA834 1117	2023-05-12

Remark: " N/A" denotes No Model No. / Serial No. and No Calibration specified.

4.9.3 TEST PROCEDURE

The EUT shall be tested for each selected combination of test levels and duration with a sequence of three dips/interruptions with intervals of 10 s minimum (between each test event). Each representative mode of operation shall be tested. Abrupt changes in supply voltage shall occur at zero crossings of the voltage waveform.

4.9.4 DEVIATION FROM TEST STANDARD

No deviation

4.9.5 TEST SETUP

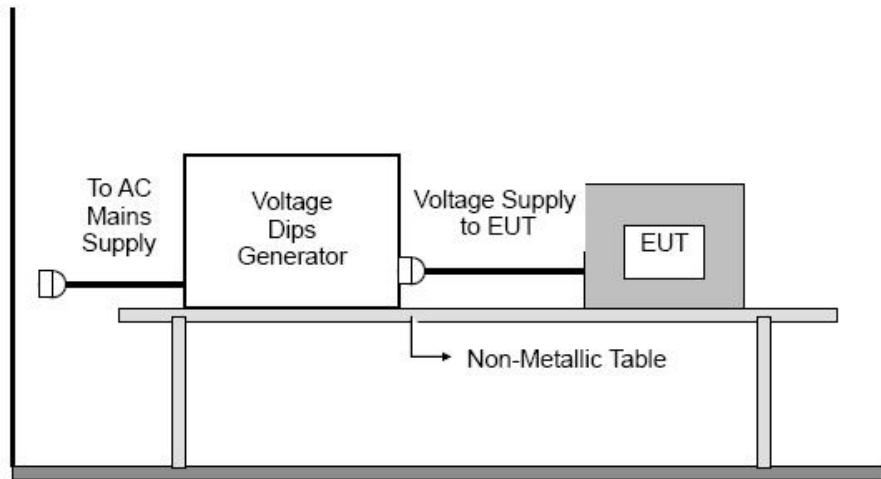

For the actual test configuration, please refer to the related Item –EUT Test Photos.

4.9.6 TEST RESULTS

Voltage Reduction	Periods	Perform Criteria	Results	Judgment
AC 240V/50Hz, AC 100V/50Hz				
Voltage dip 30%	25	C	B	PASS
Voltage dip 60%	10	C	B	PASS
Interruption100%	0.5	C	A	PASS
AC 240V/60Hz, AC 100V/60Hz				
Voltage dip 30%	30	C	B	PASS
Voltage dip 60%	12	C	B	PASS
Interruption100%	0.5	C	A	PASS

Note:

- 1) N/A - denotes test is not applicable in this test report.

5. ATTACHMENT
5.1 EUT TEST PHOTO

Conducted Emission Measurement Photo

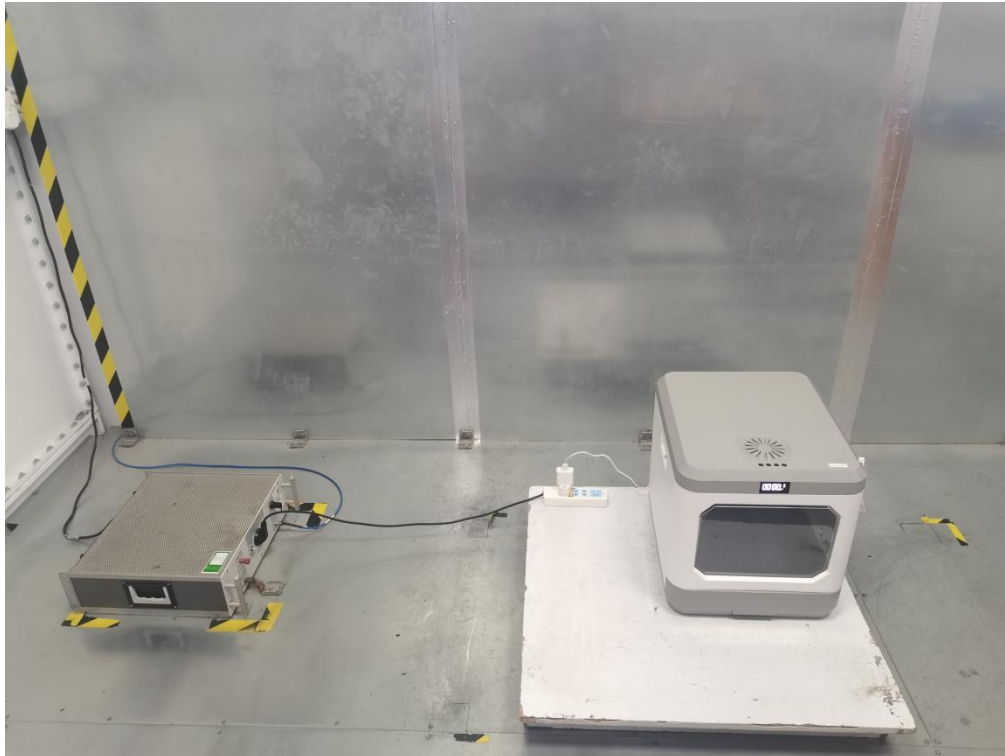

Disturbance Power Measurement Photo



ESD Measurement Photo



Surge Measurement Photo



EFT Measurement Photo

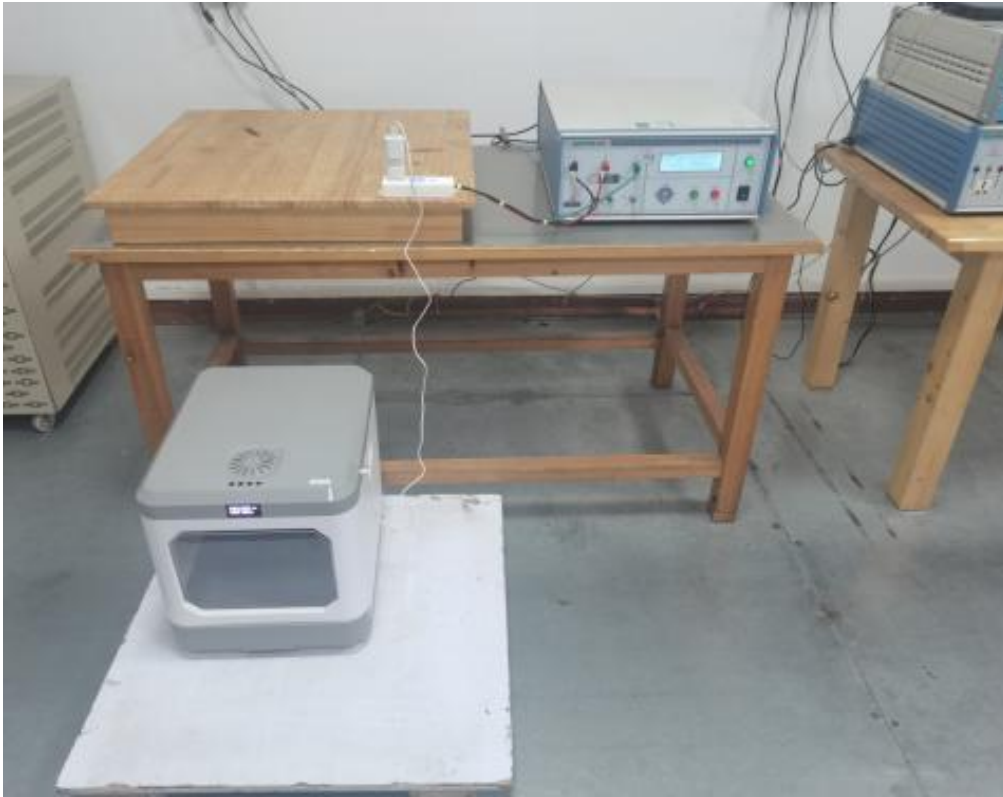

Dips Measurement Photo



Flicker Emission Measurement Photo



5.2 EUT PHOTO



Figure 1.Overall view of unit



Figure 2.Overall view of unit



Figure 3.Overall view of unit

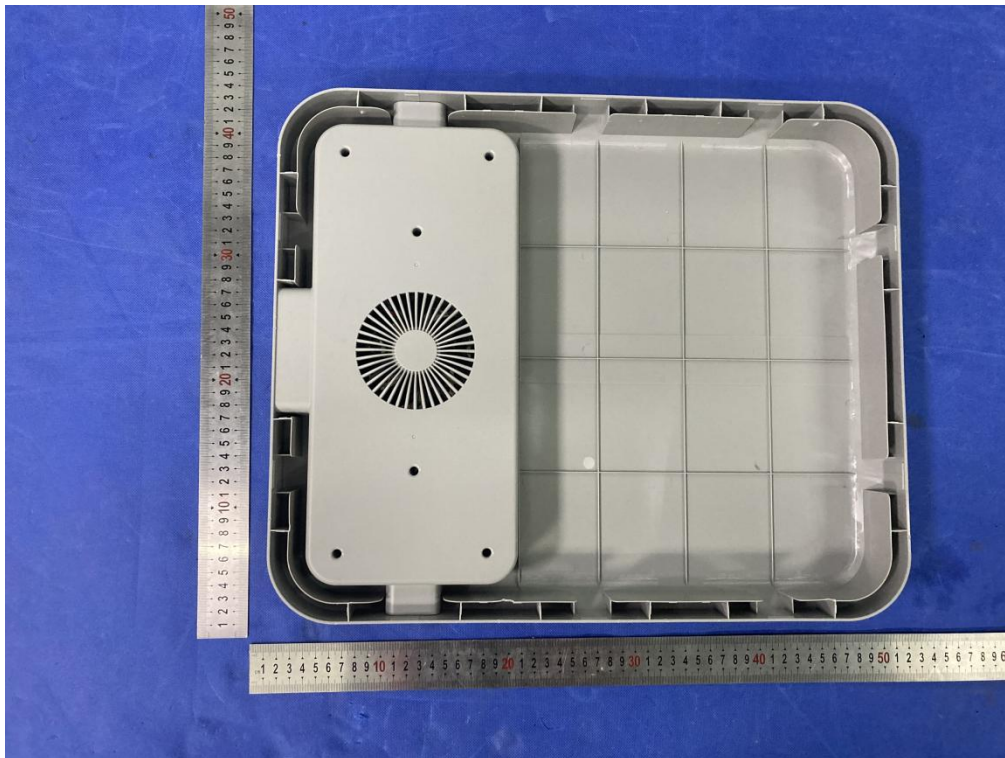

Figure 4.Inside view of unit

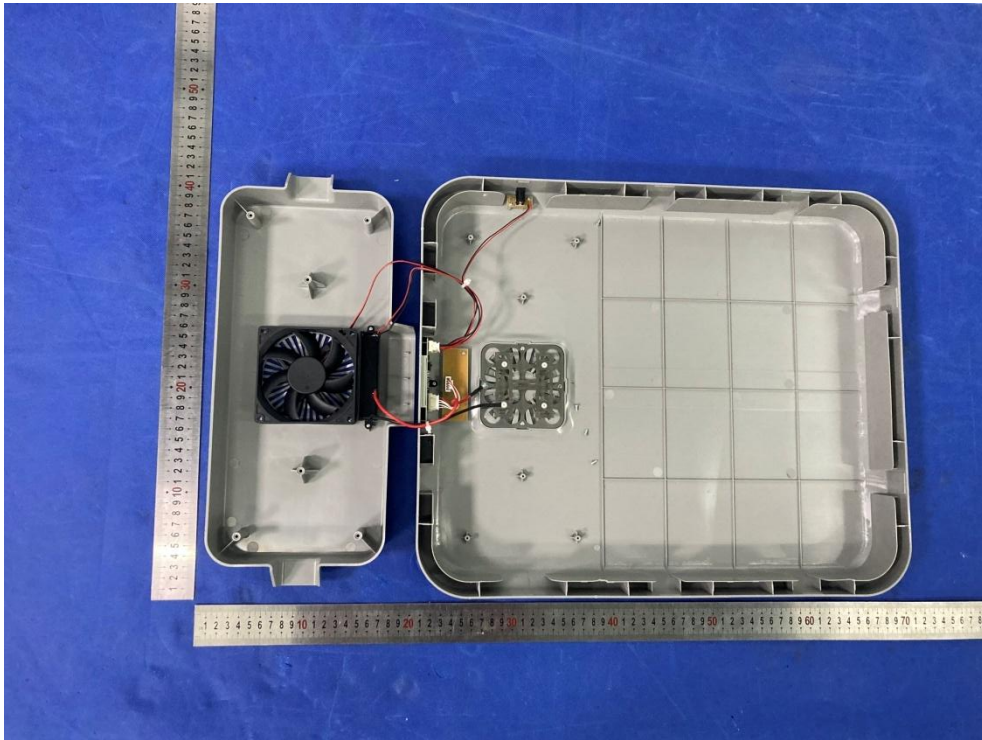

Figure 5.Inside view of unit

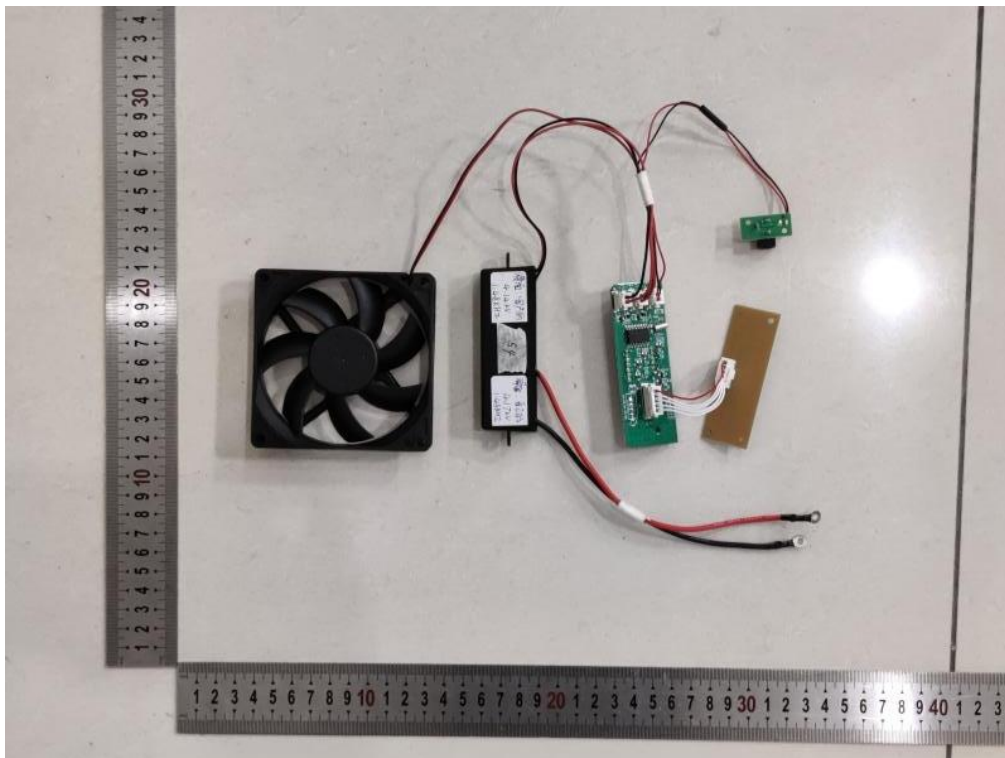

Figure 6.Inside view of unit

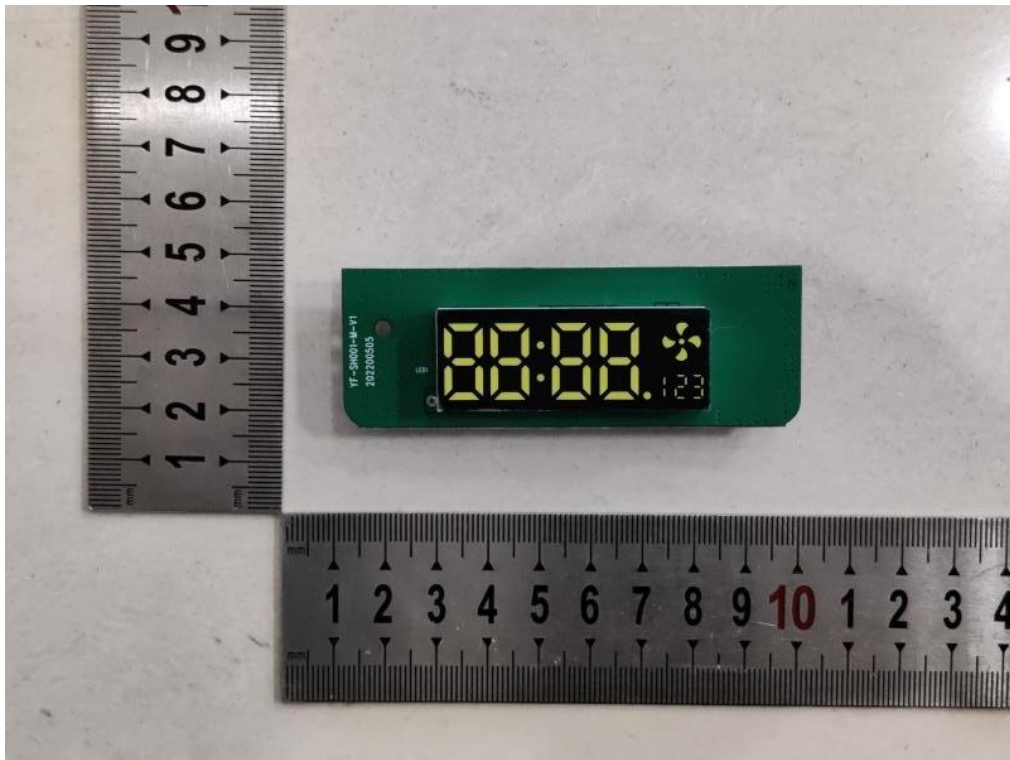

Figure 7.PCB view

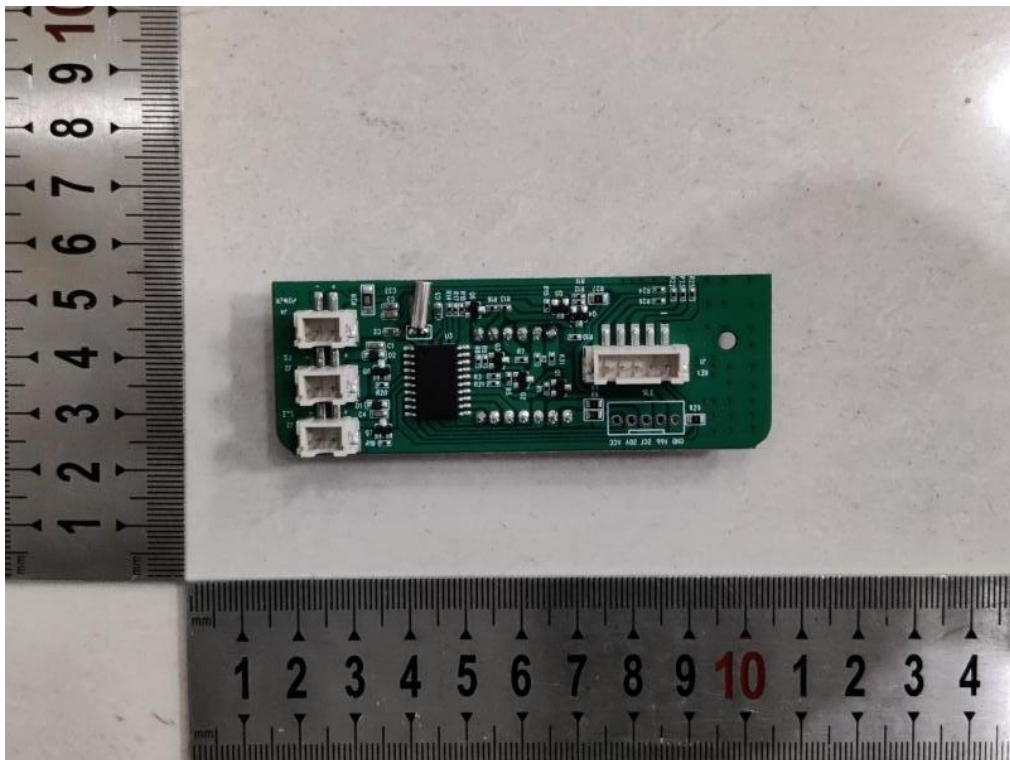

Figure 8.PCB view

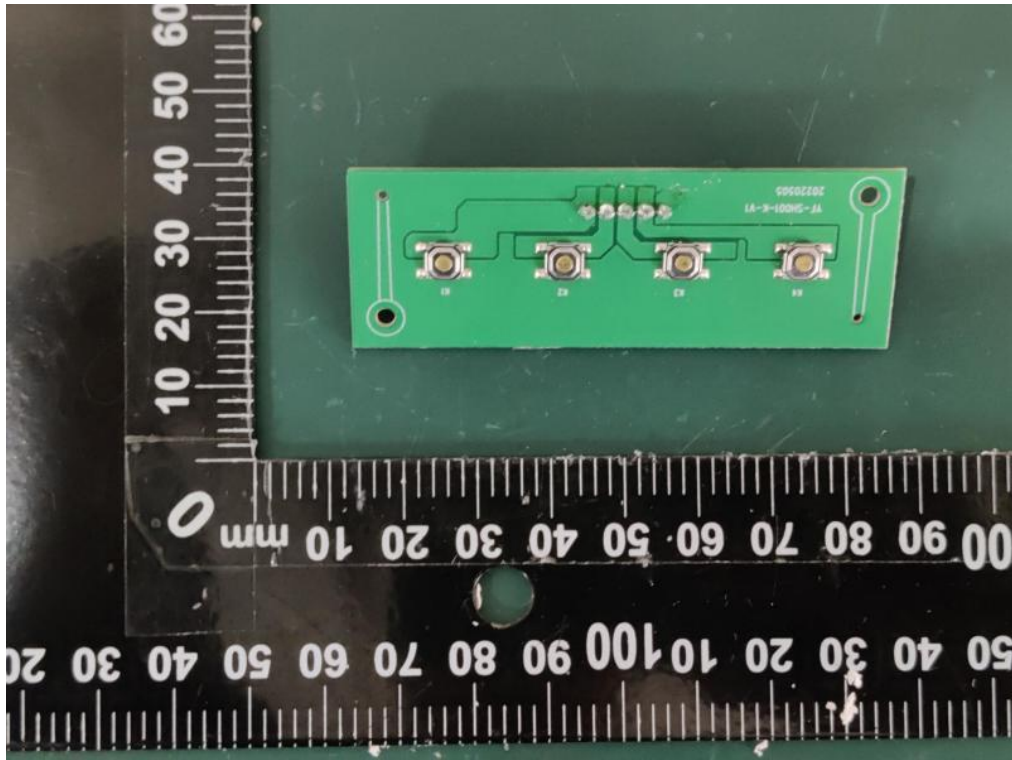

Figure 9.PCB view

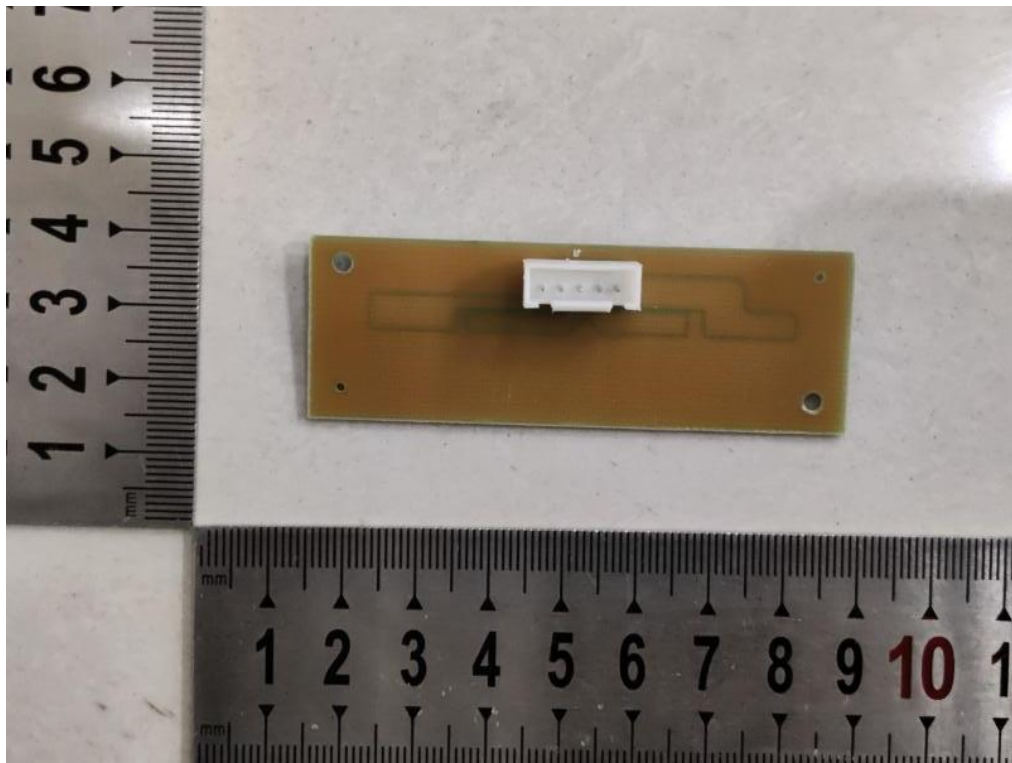

Figure 10.PCB view



Figure 11.Overall view of adapter

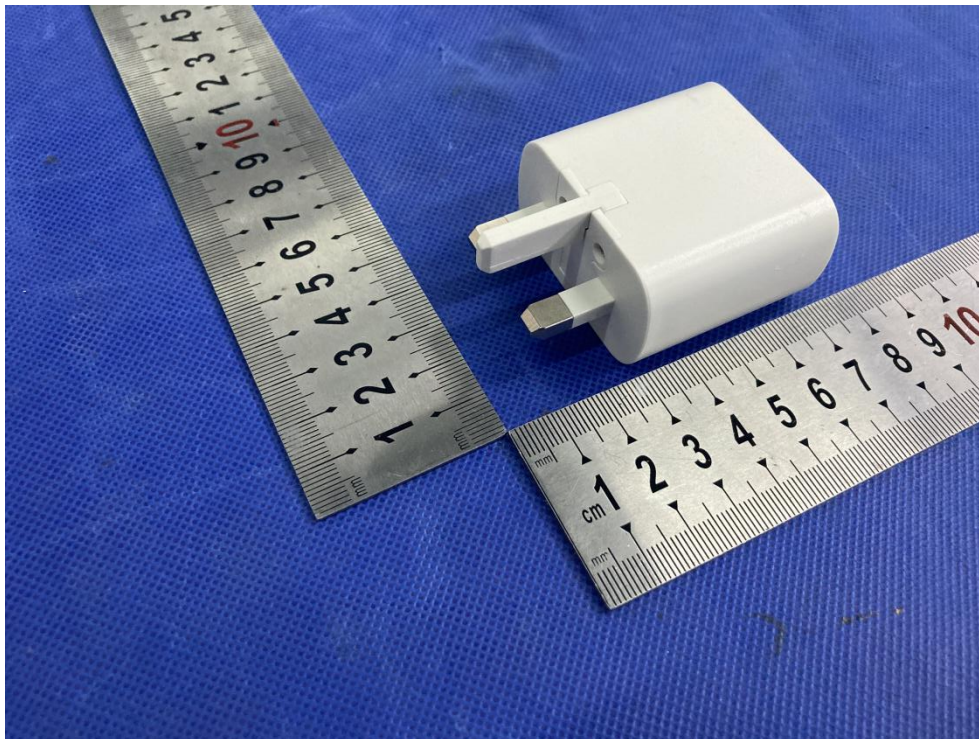

Figure 12.Overall view of adapter

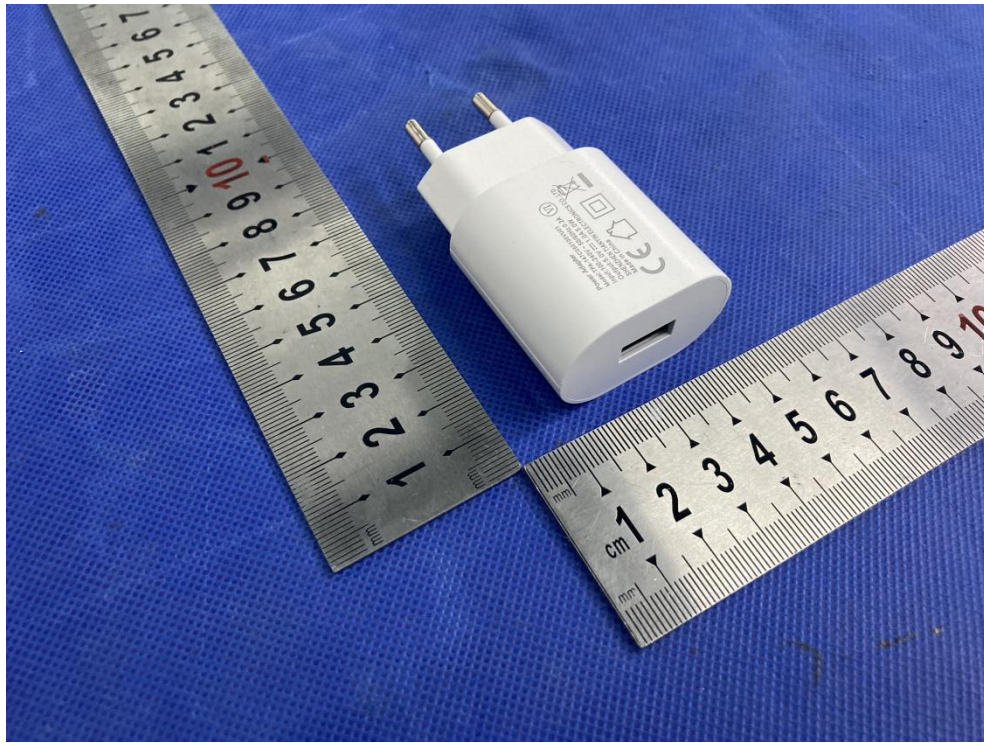

Figure 13.Overall view of adapter

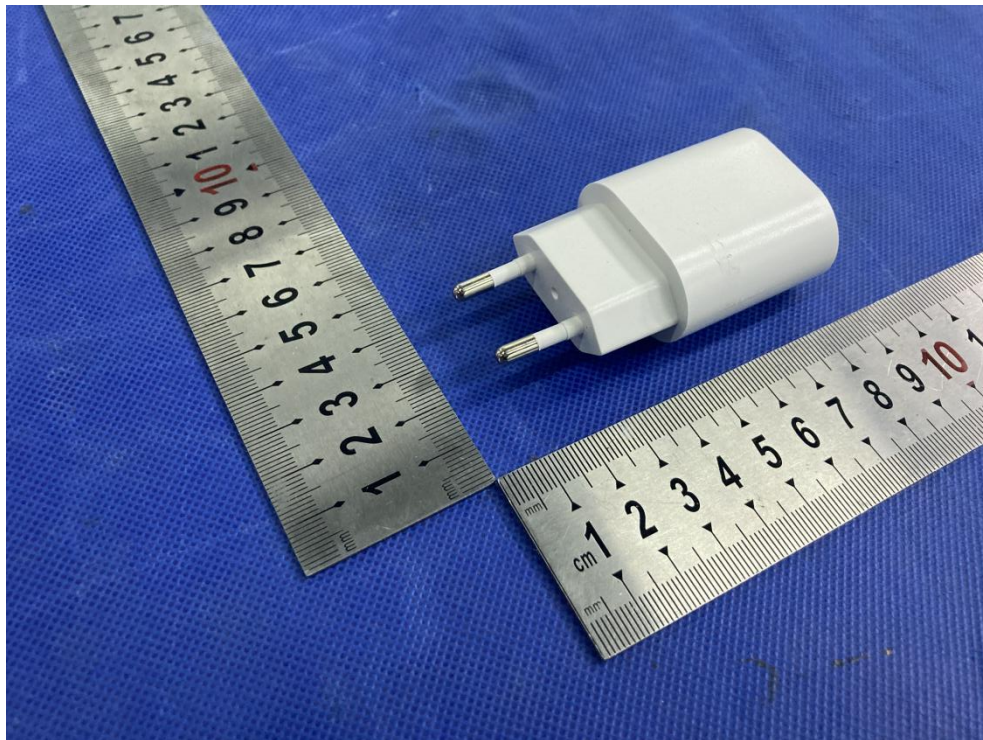

Figure 14.Overall view of adapter

***** End of Page *****