



Accurate
positioning

22°43'59.57617"N 114°03'03.61546"E



X168

Five-array Anti-jamming Receiver

Data Sheet



Shenzhen Jumpstar Technology Co.,Ltd

Email : info@jumpstar-tech.com

Tel : (86) 0755-23732282

Fax : (86) 0755-23732823

Add : Room 1305, Building A, Lechuanghui Building, No. 1211
Guanguan Road, Guanlan Street, Longhua District, Shenzhen

Table of contents

1. Functional Description	2
1.1 Overview	2
1.2 Product Characteristics	2
1.3 Performance Indicators	2
1.4 Product Application	3
2. Pin Definitions	3
2.1 Pin assignment	3
3. Mechanical properties	3
4. Mechanical dimensions	4
5. Device Connection (SBF Protocol)	4

1. Function Description

1.1 Overview

The X168 is an integrated anti-jamming antenna that combines the functions of an anti-jamming module and an array antenna. It leverages the dual advantages of an anti-jamming module and an array antenna, offering high integration, miniaturization, low power consumption, and lightweight design. It is suitable for airborne, vehicle-mounted, and portable devices, providing strong anti-jamming protection for communication in extreme scenarios and meeting the anti-jamming communication needs of various applications.

1.2 Product Characteristics

- Supported frequency bands: GPS L1/L2/L5 bands, BDS B1/B2/B3 bands, GLONASS G1/G2 bands, GALILEO E1/E5/E6 bands
- Number of anti-interference components: Five-component anti-interference device
- Interference immunity: 115dB under single interference, 95dB under three interferences.
- The equipment is highly integrated and easy to install and use.
- Smallest size: 168×168×32mm (excluding connector), weight ≤75g
- Low noise figure RF front end, high sensitivity

1.3 Performance Indicators

Parameter	Detailed Explanation	
Receive frequency	<ul style="list-style-type: none"> ■BDS: B1, B2 , B3 ■GPS:L1 , L2, L5 	<ul style="list-style-type: none"> ■GLONASS: G1, G2 ■Galileo:E1, E5, E6
Anti-interference frequency	<ul style="list-style-type: none"> ■BDS: B1, B2 , B3 ■GPS:L1 , L2, L5 	<ul style="list-style-type: none"> ■GLONASS: G1, G2 ■Galileo:E1, E5, E6
Anti-interference capability	<ul style="list-style-type: none"> Single interference Three interferences 	<ul style="list-style-type: none"> 115dB 95dB
Operating voltage	5V	
Rated power consumption	≤2W (Indoor temperature)	

1.4 Product Application

- IoT Communication
- Precision Engineering Operations
- Rail transit vehicle
- Portable mobile terminal
- Airborne
- Vehicle terminal
- Marine communications
- IoT smart terminals

2. Pin Definitions

2.1 Pin assignment

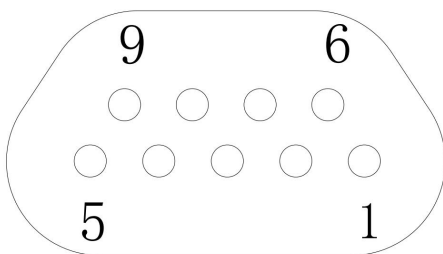

J30J-9Pins

PIN.	Name	Input/Output	Description
1	VIN+	Input	5V power input
2	GND	-	Ground
3	TX2_SBF	Output	SBF protocol output
4	TX1_NMEA	Output	NMEA protocol output

3. Mechanical properties

Parameter	Specification	Unit
Product Dimensions	168×168×32 (excluding connector)	mm
Device interface model	J30J-9TP	-
Matching plug model	J30J-9ZKL	-
Operating temperature	-40 ~ +70	°C
Weight	≤75	g

4. Mechanical dimensions

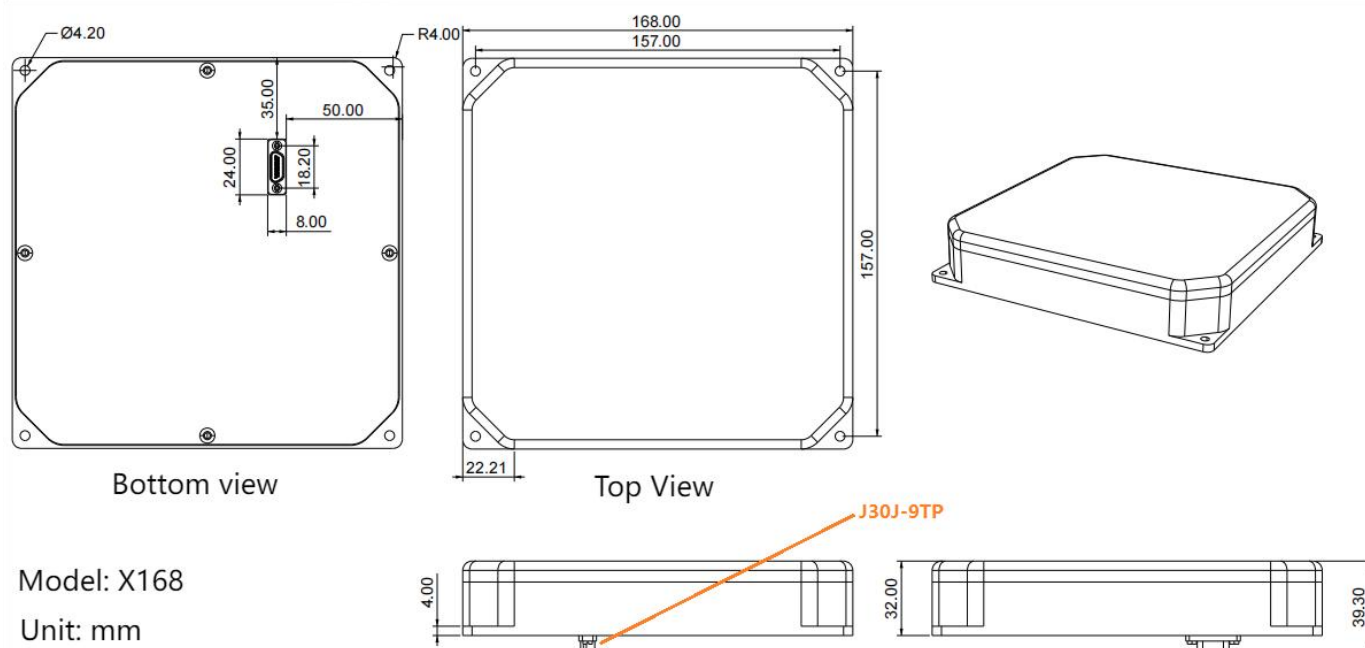

Model: X168

Unit: mm

5. Device Connection (SBF Protocol)

1) FC1P + Open Source Flight Controller

First, install the latest APM firmware.

Automatic parameter configuration is disabled; if you connect directly to the flight controller without disabling this feature, the X168's configuration will be modified and become unusable.

Set the baud rate of the X168's COM2 serial port to 230400; at the same time, the corresponding serial port of the flight controller must also be set to 230400 to handle abnormal situations when the number of satellites increases.

Set the flight controller parameter "SERIAL4_PROTOCOL" to 5.

Set the priority of "GPS_PRIMARY" to "GPS2".

Set GPS2_TYPE to 10 (corresponding to the SBF protocol).

2) V10 flight controller

Connect the configured X168 to the RTCM serial port of the V10 flight controller.

Ensure that the baud rate of the X168 is consistent with the baud rate of the V10 flight controller (115200).

Check that the X168 receiver has successfully connected to the flight controller via the ground station.

To set up flight with the X168: On the ground station's main interface, select "Factory Settings" > "Flight Settings" > "Satellite Navigation".

After completing the above steps, unlock and begin flying.

6. Notice

The bottom surface of the device is a heat dissipation surface; during installation, the bottom surface should be connected to a structure with good thermal conductivity.

During equipment installation, install conductive adhesive strips around the J30J connector .

