



JS-C8A

product specifications



Shenzhen Jumpstar Technology Co.,Ltd

Email : info@jumpstar-tech.com

Tel : (86) 0755-23732282

Fax : (86) 0755-23732823

Add : Room 1305, Building A, Lechuanghui Building, No. 1211

Guangguan Road, Guanlan Street, Longhua District, Shenzhen

Table of contents

Change revision history	3
1 Product Overview	3
1.1 Overview	4
1.2 Product features	4
1.3 Performance indicators	5
1.4 Agreement	6
1.5 antenna	6
1.6 Product Application	6
2 pin definition	6
2.1 Pin assignment	7
3 Electrical specifications	8
4 Mechanical specifications	9
5 application circuit	10
6RoHS	11
7 Recommended temperature profile for reflow soldering	11

1 Product Overview

1.1 Overview

JS-C8A is a small-sized, high-precision positioning module with multi-frequency points in the whole system. It supports signal tracking of satellite navigation systems such as BDS-2, BDS-3, GPS, GLONASS, Galileo, SBAS and QZSS. It has onboard inertial navigation devices and is very suitable for Beidou. The large-scale application of the product supports combined navigation algorithms and is suitable for fields such as intelligent driving, drones, and intelligent robots.

1.2 Product Features

- Small size and high precision
- With inertial guidance
- Multiple frequency points throughout the system, supporting Beijing III
- With antenna detection
- Multiple interfaces
- Supports BDS, GPS, GLONASS, Galileo, SBAS and QZSS
- Capable of suppressing potential narrowband and single-tone radio interference signals within the GNSS signal band
- Mainstream package (22mm x 17mm x 2.8mm±0.3mm), compact size, suitable for space sensitive applications
- Supports NMEA 0183 protocol

1.3 Performance indicators

category	Specification
Receive constellation frequency points	■GPS: L1C/A, L2P, L2C ■BDS-2:B1I,B2I ■BDS-3:B1C,B2b ■GLONASS:G1,G2 ■Galileo:E1,E5b ■QZSS:L1C/A,L2C ■SBAS:L1C/A
Sensitivity	Tracking and Navigation-155dBm Capture -138dBm
First positioning time 1	Cold start < 20 s Warm start <10 s (using RTC) RTK initialization < 5 s (baseline length less than 10km) Lost lock and recapture <1s
Accuracy	Single point positioning $H \leq 1.5m, V \leq 3m$ ($1\sigma, PDOP \leq 4$) RTK $H \pm (8 + 10^{-6} \times D)$ mm $V \pm (15 + 10^{-6} \times D)$ mm D is the baseline length (unit: mm)
Measurement accuracy	Pseudo range accuracy $\leq 10cm$ Carrier phase accuracy $\leq 1mm$
Speed accuracy measurement	$\leq 0.02m/s$
Timing accuracy	20ns
Gyro	Measuring range $250^\circ/s$ Zero deviation in the whole process is $0.5^\circ/s$
acceleration	Measuring range 4g 20mg of zero deviation throughout the process
inertial navigation	The GNSS antenna signal loses lock for 3 seconds, and the accuracy remains cm level The GNSS antenna signal loses lock for 10 seconds, and the accuracy remains m level
data rate	Measurement & positioning 100Hz (optional) RTK positioning 20Hz (optional)

① -130dBm, 12 satellites in use

1.4 Agreement

protocol	type
NMEA 0183	GPGGA,GPGSV,GPGLL,GPGSA,GPGST,GPHDT,GPRMC,GPVTG,GPZDA
(CNB) binary format	custom binary
CMR(GPS)	CMROBS, SMRREF
RTCM2.X	RTCM1,RTCM3,RTCM9,RTCM1819,RTCM31,RTCM41,RTCM42
RTCM3.X	1004~1008,1012,1019,1020,1033,1042,1045/1046,1230,4078 MSM3~MSM7:1073~1077,1083~1087,1123~1127,1093~1097

1.5 antenna

parameter	Specification
Antenna interface	Impedance matching wiring 50Ω impedance matching External power supply +3.3V~+5V±5%VDC @0-100mA Antenna gain recommended 20~35dB

1.6 Product Application

- Intelligent driving • Automotive applications
- Maritime navigation, fleet management
- Emergency Rescue
- Drones
- Personal protection
- Car navigation and tracking

2 pin definition

2.1 Pin assignment

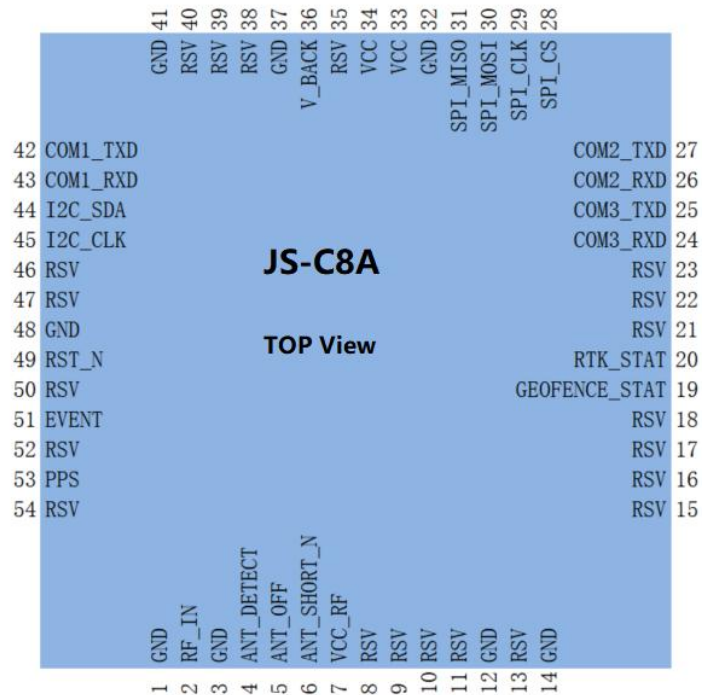

Pin number	Pin name	I/O	describe
1,3,12,14,32,37,41,48	GND	G	land
2	RF_IN	I	GNSS signal input
4	ANT_DETECT	I	Antenna open circuit detection (default high level)
5	ANT_OFF	O	External low-noise amplifier enable (default high level)
6	ANT_SHORT_N	I	Antenna short circuit detection(Default high level)
7	VCC_RF	O	External low noise amplifier power supply
8,9,10,11,13,15,16,17,18,21,22,23,35,38,39,40,46,47,50,52,54	RSV	-	reserved pin
19	GEOFENCE_STAT	O	Geofencing (user defined)
20	RTK_STAT	O	Flashing (high level is active when receiving RTCM data and performing RTK solution)
twenty four	COM3_RXD	I	UART 3 input
25	COM3_TXD	O	UART 3 output
26	COM2_RXD	I	UART 2 input

27	COM2_TXD	O	UART 2 output
28	SPI_CS	I/O	SPI_CS
29	SPI_CLK	I/O	SPI_CLK
30	SPI_MOSI	I	SPI_MOSI
31	SPI_MISO	O	SPI_MISO
33,34	VCC	P	Main power input
36	V_BCKP	P	Backup power input
42	COM1_TXD	O	UART 1 output
43	COM1_RXD	I	UART 1 input
44	I2C_SDA	I/O	I2C data
45	I2C_CLK	I/O	I2C clock
49	RST_N	I	reset
51	EVENT	I	External interrupt input
53	PPS	O	second pulse

When the user integrates the module and connects an external high-gain choke coil antenna, if a surge protector is not added, it will easily cause damage to the feed current limiting chip inside the module. It is recommended that users install a surge protector on the antenna when connecting a high-gain choke antenna.

3 Electrical Specifications

Parameter	symbol	smallest	typical	maximum	unit
Supply voltage	VCC		3.3±5% DC		V
Power consumption	Anti-interference function is not turned on		0.8 @3.3V±5%DC		W
	Turn on anti-interference function		0.9 @3.3V±5%DC		W
Input high voltage	V _{IH}	2.0	-	-	V
Input low voltage	V _{IL}	-0.3	-	0.8	V
High level output voltage	V _{OH}	2.9	-	-	V
Low level output voltage	V _{OL}	-	-	0.4	V
Pull current	I _{OH}	8	-	-	mA
Sink current	I _{OL}	8	-	-	mA
Storage temperature	T _{st}	-55		95	°C
Operating temperature	T _{opr}	-40		85	°C
Humidity				95	%

Note: VCC main power supply, voltage range: 3.3V (DC). Voltage ripple and spikes are required to be less than 50mV. VCC_RF antenna feed, voltage range: 3.3V ~ 5.5V (DC). Voltage ripple and spikes are required to be less than 50mV. V_BCKP, voltage 1.8V~3.6V, voltage ripple and spike pulse are required to be less than 30mV.

4 Mechanical specifications

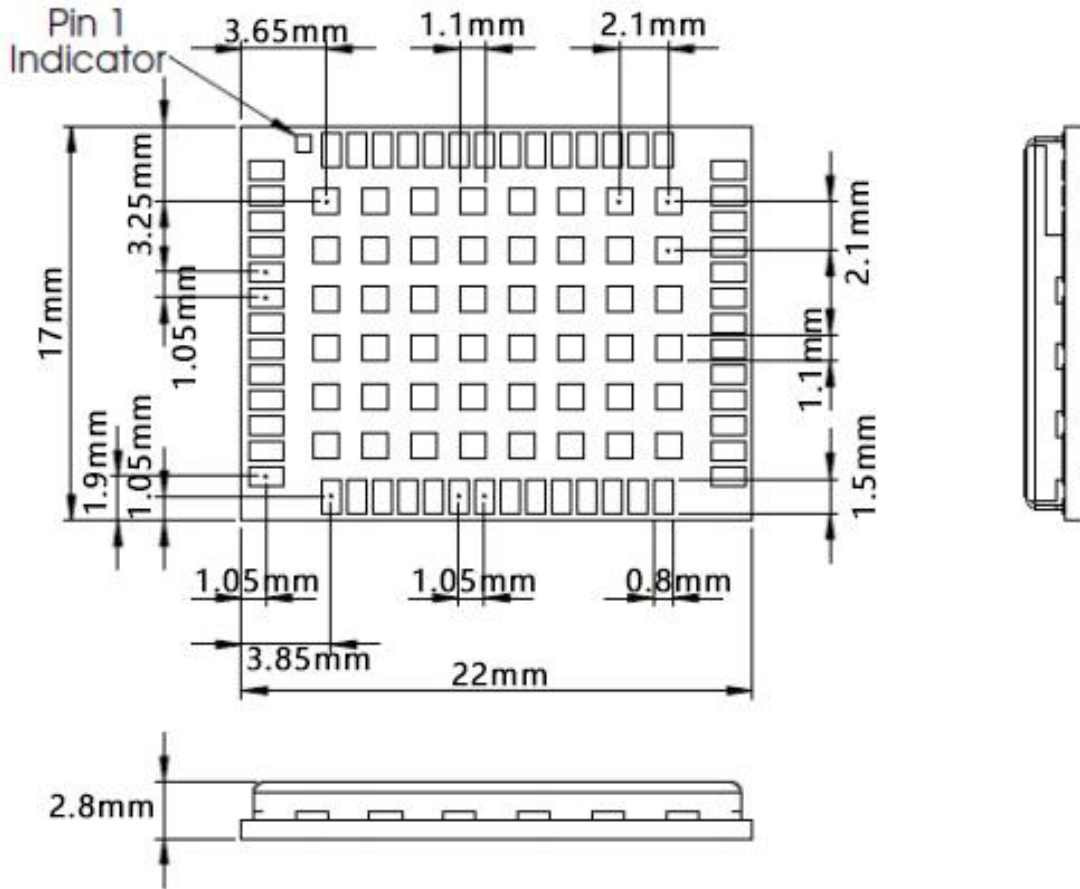

Unit: mm Dimensional error: $\pm 0.3\text{mm}$



5 Application circuit

This section provides a C8A module application connection example in the form of a specific circuit.

Referring to the diagram below, you can easily establish a communication circuit between the C8A

module and other terminals (such as PC, GPRS module, Bluetooth module or other devices with UART).

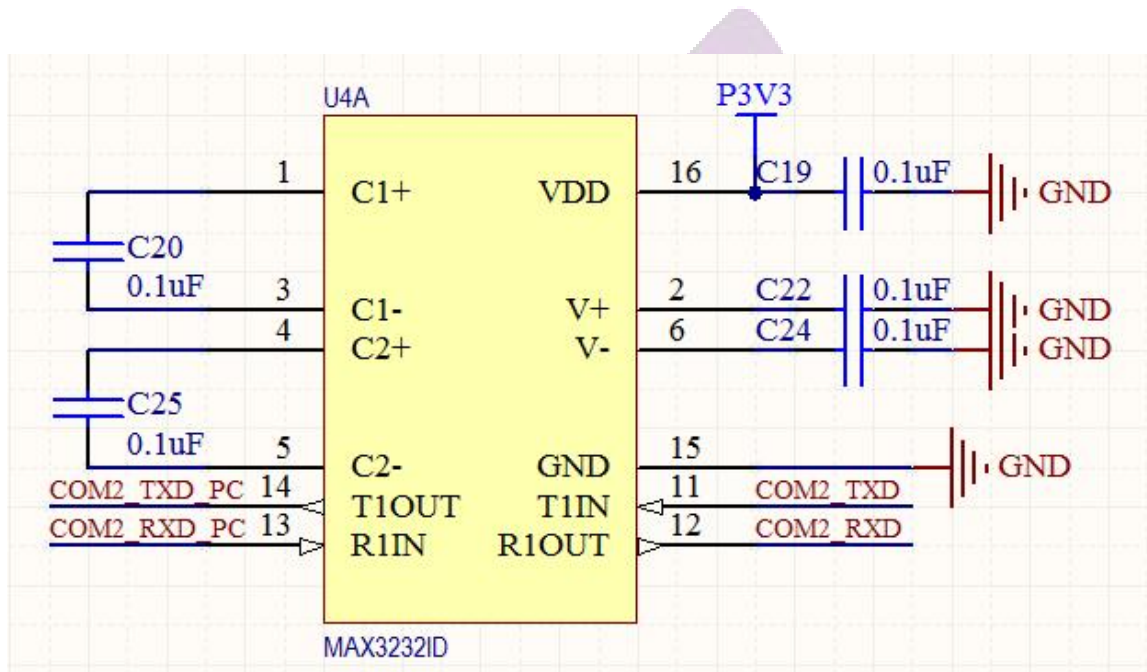

6RoHS

This product complies with RoHS standards

7 Recommended temperature profile for reflow soldering

This is a surface mount module and it is recommended to use SMT welding for assembly.

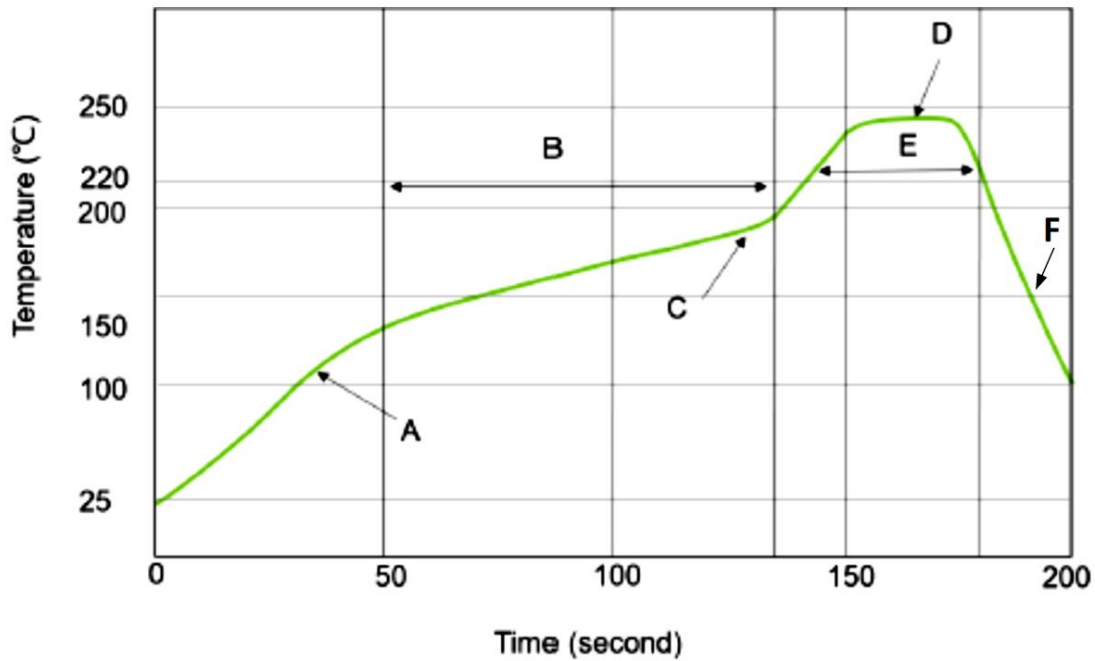

Furnace temperature curve

The process temperature limits are as follows:

A: Heating area: slope: 1 ~ 3 °C/sec

B: Constant temperature zone: 150-190 °C Time: 80-110 S

C: Constant temperature → reflow zone: slope: 1 ~ 3 °C/sec

D: Peak temperature: 235-245 °C

E: Reflow area: greater than 220 °C time: 50-80 S

F: Decline slope: -5 ~ -1 °C/sec

To avoid damage to the module due to repeated heat exposure, it is recommended to attach the module after completing the reflow soldering on the first side of the PCB board.

When disassembling the module, please use a BGA rework station, select an air nozzle of appropriate size and use an appropriate temperature curve. The maximum temperature shall not exceed 245°C, and the temperature rise slope shall not exceed 3°C/s.